



UNIVERSITY OF CALICUT

Abstract

General and Academic - Faculty of Science - Syllabus of BSc Electronics Programme (LRP) under CBCSS UG Regulations 2019 with effect from 2019 Admission onwards - Anomalies rectified - Approved - Orders Issued.

G & A - IV - J

U.O.No. 10290/2020/Admn

Dated, Calicut University.P.O, 05.11.2020

- Read:-*
1. U.O.No. 8962/2019/Admn dtd 07.07.2019
 2. U.O.No. 5194/2020/Admn Dated, 08.06.2020
 3. Remarks sought on the file No.134729/EX-I-ASST-1/2019/PB
 4. Item No.1&2 in the minutes of the meeting of the Board of Studies in Electronics held on 22.08.2020
 5. Item No.I.8 in the meeting of Faculty of Science held on 08.09.2020
 6. Item No.II.I in the minutes of the meeting of the Academic Council held on 01.10.2020
 7. Orders of the Vice-chancellor in file no. 191466/GA-IV-J1/2019, dt.d 07.10.2020

ORDER

1. The scheme and Syllabus of BSc Electronics Programme (LRP) under CBCSS UG Regulations 2019, with effect from 2019 Admission onwards, were implemented, vide paper read (1) and modified as vide paper read (2) above.
2. The meeting of Board of Studies in Electronics held on 22.08.2020, vide paper read (4) above, resolved to rectify the anomalies occurred in the syllabus, pointed out by Pareeksha Bhavan, vide paper read (3) above, as follows:
 - To allot 75 marks for Practical examination (credit 2/3), as per UGC Regulation of UG-CBCSS-2019. (External mark-60 and Internal marks-15)
 - To conduct an external viva-voce for the Skill development Lab in 4th semester and maximum marks to be given as 50. (External marks-40 and Internal marks-10). The duration of all Practical Exams is 3 hours.
3. The Faculty of Science at its meeting held on 08.09.2020 approved the minutes of the meeting of the Board of Studies in Electronics (Single Board), vide paper read (5) above.
4. The Academic Council, vide paper read (6), resolved to approve the anomaly rectified Syllabus of B.Sc Electronics Programme and the Vice Chancellor has accorded sanction to implement the Academic Council decision, vide paper read (7) above.
5. Sanction is therefore accorded to implement the anomaly rectified Syllabus of B.Sc Electronics Programme under CBCSS UG Regulations, with effect from 2019 Admission.
6. The corrected syllabus of B.Sc Electronics Programme (LRP) under CBCSS UG Regulations 2019 with effect from 2019 admission onwards, is therefore implemented.
7. U.O.No. 5194/2020/Admn Dated, 08.06.2020 stands modified to this extent. (Corrected Syllabus appended)

Arsad M

Assistant Registrar

To

The Principals of all Affiliated Colleges
Copy to: PS to VC/PA to PVC/ PA to Registrar/PA to CE/JCE I/JCE IV/DoA/EX and EG
Sections/GA I F/CHMK Library/Information Centres/SF/DF/FC

Forwarded / By Order

UNIVERSITY OF CALICUT



SYLLABUS

For

B.Sc. ELECTRONICS

(CBCSS UG 2019)

Under Choice Based Credit Semester System

(w.e.f. 2019 admission)

Board of Studies in Electronics
University of Calicut

UNIVERSITY OF CALICUT

B.Sc. ELECTRONICS

**CORE AND COMPLEMENTARY
PROGRAMMES**

**STRUCTURE, SCHEME and
SYLLABUS**

2019 Admission Onwards

REGULATIONS GOVERNING

BACHELOR OF SCIENCE IN ELECTRONICS

1.0 Title of the programme:

This programme shall be called **BACHELOR OF SCIENCE IN ELECTRONICS** under Choice Based Credit and Semester System for Undergraduate (UG) Curriculum -2019.

1.0 Title of the programme:

This programme shall be called **BACHELOR OF SCIENCE IN ELECTRONICS** under Choice Based Credit and Semester System for Undergraduate (UG) Curriculum -2019.

2. Highlights of the programme

2.1 Aim and objective:

Emerging trends and stimulating developments in the field of science, increasing opportunities and demands at workplace have made it imperative that the undergraduate science courses be redesigned to cater to the professional aspirations of the students. The present world is in need of professionals who are experts in the respective fields and hence restructuring of any science course should possess components as catalyst to achieve the goals. The boundaries between different domains of science are disappearing and more exciting developments are being reported from areas at the crossing point of disciplines. In response to these changes taking place in society, the University of Calicut has embarked on a major restructuring exercise for its science courses, introducing BSc courses in alternate pattern.

BSc ELECTRONICS Programme is one such course in science stream under Choice Based Credit and Semester System of University of Calicut. This restructured undergraduate science course provides students with a broad exposure to the critical domains of sciences with adequate background of mathematical sciences. The tools and techniques of computer applications, industry automation, electronics and analytical techniques have a major role in the curriculum. The audit courses offered ensure adequate exposure to global and local concerns that explore the many aspects of societal relevance and environmental awareness. It also gives opportunity to explore the multi-disciplinary nature of science.

This course is to equip 10+2 (Science Group) students with the theory of Electronic Science and also to train them in achieving technical expertise in Electronic Application. We aim to provide a solid foundation in all aspects of Electronics and to show a broad spectrum of modern trends in the subject and also to develop experimental, computational and mathematical skills of students. The

syllabi are framed in such a way that it generates graduates of the calibre sought by industries and public service as well as academic teachers and researchers of the future.

2.2 Programme Outcome:

On completion of the B.Sc Electronics Programme, the student will:

- Have basic communicative skill in the English language
- Have environmental and civic awareness
- Communicative skills and literary sensibility in languages other than English
- Have sound knowledge of the theory behind core subjects like, Electronic components, Electronic measuring and testing instruments, Analog and Digital IC's, Electronic circuit design and implementation, Troubleshooting and maintenance of electronic and electrical devices.
- Have sound skills in assembly Language and High Level Language programming, interfacing of electronic devices with computers, etc.
- Be in a position to develop industrial and entrepreneur applications.

2.3 Higher Studies: These students can continue to take up courses such as MSc Electronics, MSc Instrumentation Technology, MCA, MBA, etc.

2.4 Eligibility

Candidate of admission to the B.Sc. Electronics Programme should have passed the Higher secondary / Technical higher secondary / Vocational Higher secondary examinations of Govt. of Kerala or CBSE or ICSE or any other examinations recognized as equivalent to by the University of Calicut with Mathematics or Electronics or Computer Science or Computer Applications as one of the optional subjects.

2.5 Duration of the Programme

Duration of the programme shall be 6 semesters. Each semester should have 90 instructional days with 5 hours of instruction per day 5-days a week system. The University will conduct semester-end examinations.

Programme Structure

Semester	Course No.	Courses	Course Code	Course Title	Contact Hours			credits
					Theory	Lab	Total	
Semester I	1	Common Course 1		English course I	5	-	5	3
	2	Common Course 2		English course II	4	-	4	3
	3	Common Course 3		Additional Language course I	5	-	5	4
	4	Core Course 1	ELE1B01	Basic Electronics and Network Theorems	1	2	3	2
	5	1 st Complimentary Course 1	MTS1C01	Mathematics – I	4	-	4	3
	6	2 nd Complimentary Course 1		Optional-1	4	-	4	3
	7	Audit course		Environment Science	-	-	-	4*
Total							25	18
Semester II	1	Common Course 4		English Course III	5	-	5	4
	2	Common Course 5		English Course IV	4	-	4	4
	3	Common Course 6		Additional Language course III	5	-	5	4
	4	Core Course 2	ELE2B02	Electronic Circuits	1	2	3	2
	5	Core Lab 1 (Exam)	ELE2B03	Basic Electronics and Network Theorems Lab	I Sem Lab Exam			2
	6	Core Lab 2 (Exam)	ELE2B04	Electronic Circuits Lab	II Sem Lab Exam			2
	7	1 st Complimentary Course 2	MTS2C02	Mathematics -II	4	-	4	3
	8	2 nd Complimentary Course 2		Optional-2	4	-	4	3
	9	Audit course		Disaster Management	-	-	-	4*
Total							25	24

***not added to Total Credit**

Semester	Course No.	Courses	Course Code	Course Title	Contact Hours			Credits
					Theory	Lab	Total	
Semester III	1	General Course I (Common to LRP group of boards)	A11	Python Programming	4	-	4	4
	2	General Courser-II (Common to LRP group of boards)	A12	Sensors and Transducers	4	-	4	4
	3	Core Course 3	ELE3B05	Digital Electronics	4	2	6	3
	4	Core Lab 5		Skill Development Lab 1	-	1	1	-
	5	1 st Complimentary Course 3	MTS3C03	Mathematics –III	5	-	5	3
	6	2 nd Complimentary Course 3		Optional-3	5	-	5	3
	7	Audit course		Human Rights/Intellectual Property Rights/ Consumer Protection	-	-	-	4*
Total							25	17
Semester IV	1	General Course –III (Common to LRP group of boards)	A13	Data Communication & Optical Fibers	4	-	4	4
	2	General Course –IV (Common to LRP group of boards)	A14	Microprocessors – Architecture and Programming	4	-	4	4
	3	Core Course 4	ELE4B06	Analog Integrated Circuits	4	2	6	3
	4	Core Lab 3	ELE4B07	Digital Electronics Lab	III Sem. Lab Exam			2
	5	Core Lab 4	ELE4B08	Analog Integrated Circuits Lab	IV Sem. Lab exam			2
	6	Core Lab 5 (3rd and 4th Sem. Lab exam + Mini Project)	ELE4B09	Skill Development Lab	-	1	1	1
	7	1 st Complimentary Course-4	MTS4C04	Mathematics-IV	5	-	5	3
	8	2 nd Complimentary Course-4		Optional-4	3	2	5	3
	9	Audit course		Gender Studies/ Gerontology	-	-	-	4*
Total							25	22

17

22

Semester	Course No.	Courses	Course Code	Course Title	Contact Hours			Credits
					Theory	Lab	Total	
Semester V	1	Core Course-5	ELE5B10	Electromagnetic Theory	4	-	4	4
	2	Core Course-6	ELE5B11	Microcontroller & Interfacing	4	3	7	3
	3	Core Course-7	ELE5B12	Network Theory	4	-	4	4
	4	Open Course (Choose a Course from the List)	ELE5D01	Computer Hardware	3	-	3	3
			ELE5D02	Digital Fundamentals				
			ELE5D03	Electronics Fundamentals				
	5	Core Lab -6		Microprocessor programming and interfacing lab (8085 and raspberry pi)	-	3	3	-
7	Core Lab -9		Industrial Visit & Project Work	-	4	4	-	
Total							25	14
Semester VI	1	Core Course-8	ELE6B13	Communication System	4	3	7	4
	2	Core Course-9	ELE6B14	Principles of DSP	4	3	7	4
	3	Core Course-10	ELE6B15	Microwave Theory and Techniques	4	-	4	4
	4	Core Course Elective	Choose a Course(Elective)		3	-	3	3
			ELE6B16a	Optical Communication				
			ELE6B16b	Industrial Electronics				
			ELE6B16c	Control Systems				
	4	Core Course Elective	ELE6B16d	Verilog & FPGA Based System Design				
	5	Core Lab -6	ELE6B17	Microprocessor & Microcontroller programming and interfacing lab (8085,raspberry pi,8051 and Arduino)	V and VI Sem Lab Exam			3
	6	Core Lab -7	ELE6B18	Communication system Lab	VI Sem Lab Exam			2
7	Core Lab -8	ELE6B19	Principles of DSP lab	VI Sem Lab Exam			2	
8	Core Lab -9	ELE6B20	Industrial Visit Report (1 credit) & Project Work (2 credit) Viva Voce	0	4	4	3	
Total							25	25

For Courses with credit 1, Marks – 50 (External – 40, Internal – 10)
For Courses with credit 2/3, Marks – 75 (External – 60, Internal – 15)
For Courses with credit 4/5, Marks – 100 (External – 80, Internal – 20)

Core Labs

Practical examinations shall be conducted in the even semester (II, IV, and VI).
Duration of Practical examinations is 3hours

SEMESTER II	Core Lab1	ELE2B03	Basic Electronics and Network Theorems Lab
	Core Lab2	ELE2B04	Electronic Circuits Lab
SEMESTER IV	Core Lab3	ELE4B07	Digital Electronics Lab
	Core Lab4	ELE4B08	Analog Integrated Circuits Lab
	Core Lab5	ELE4B09	Skill Development Lab
SEMESTER VI	Core Lab6	ELE6B17	Microprocessor & Microcontroller programming and interfacing lab (8085,raspberry pi,8051and Arduino)
	Core Lab7	ELE6B18	Communication system Lab
	Core Lab8	ELE6B19	Principles of DSP lab
	Core Lab9	ELE6B20	Industrial Visit Report & Project Work Viva Voce

Course Evaluation (Theory)

The evaluation scheme for each course shall contain two parts

1) Internal assessment 2) External Evaluation

20% weight shall be given to the internal assessment. The remaining 80% weight shall be for the external evaluation.

Internal Assessment

20% of the total marks in each course are for internal examinations. The internal assessment shall be based on a predetermined transparent system involving written tests, Class room participation based on attendance in respect of theory courses and lab involvement/records attendance in respect of Practical Courses.

Components with percentage of marks of Internal Evaluation of Theory Courses are-

Test paper	40%
Assignment	20%
Seminar	20%
Class room participation based on attendance	20%

For the test paper marks, at least one test paper should be conducted. If more test papers are conducted, the mark of the best one should be taken. There shall not be any chance for improvement for internal marks.

The Split up of marks for Test paper and Class Room Participation (CRP) for internal evaluation are as follows.

Split up of marks for Test paper

Split up of marks for Test paper	Out of 8 (Maximum internal marks is 20)	Out of 6 (Maximum internal marks is 15)
Less than 35%	1	1
35%- 45%	2	2
45% - 55%	3	3
55% - 65%	4	4
65% -85%	6	5
85% -100%	8	6

Split up of marks for Class Room Participation

Range of CRP	Out of 4 (Maximum internal marks is 20)	Out of 3 (Maximum internal marks is 15)
50% ≤CRP <75%	1	1
75% ≤CRP <85%	2	2
85 % and above	4	3

Course Evaluation (Practical Examination)

The practical examinations for the complementary and core courses shall be conducted by the University at the end of semesters 2, 4 and 6 respectively. The examiners shall be selected from a panel of experts prepared by the University. For each examination centre there shall be one external examiner (Chief) and one internal examiner (Additional).

For the evaluation of practical examination 20% weightage is given for internal assessment and 80% weightage is given for university exam. Record 60% lab involvement 40% as far as internal is concerned. (If a fraction appears in internal marks, nearest whole number is to be taken).

Refer CBCSS UG Regulations 2019 for more details.

Course Evaluation (Projects)

1. Evaluation of the Project Report shall be done under Mark System.
2. The evaluation of the project will be done at two stages:
 - Internal Assessment (supervising teachers will assess the project and award internal Marks)
 - External evaluation (external examiner appointed by the University)
3. Marks secured for the project will be awarded to candidates, combining the internal and external Marks
4. The internal to external components is to be taken in the ratio 1:4. Assessment of different components may be taken as below.

Internal (20%)		External (80%)	
<i>Components</i>	% of Marks	<i>Components</i>	% of Marks
Punctuality and Log Book	20	Relevance of the Topic, Statement of Objectives, Methodology (Reference/ Bibliography)	20
Skill of doing project work	20	Presentation, Quality of Analysis/Use of Statistical tools, Findings and recommendations	30
Scheme/Organization of Report	30		
Viva-Voce	30	Viva-Voce	50

- External Examiners will be appointed by the University from the list of VI semester Board of Examiners in consultation with the Chairperson of the Board.
- The chairman of the VI semester examination should form and coordinate the evaluation teams and their work.
- Internal Assessment should be completed 2 weeks before the last working day of semester.
- In the case of courses with practical examination, project evaluation shall be done along with practical examinations.
- Chairman Board of Examinations, may at his discretion, on urgent requirements, make certain exception in the guidelines for the smooth conduct of the evaluation of project.

PASS CONDITIONS

- Submission of the Project Report and presence of the student for viva are compulsory for internal evaluation. No marks shall be awarded to a candidate if she/ he fail to submit the Project Report for external evaluation.
- The student should get a minimum P Grade in aggregate of External and Internal.
- There shall be no improvement chance for the Marks obtained in the Project Report.
- In the extent of student failing to obtain a minimum of Pass Grade, the project work may be re-done and a new internal mark may be submitted by the Parent Department. External examination may be conducted along with the subsequent batch.

Semester	Credit for					Total	Hours for Core			Hours for			Total Hours per week
	Core	Complimentary	English	SL	General		Theory	Lab	Total	English	SL	Complimentary	
I	2	6	6	4	-	18	1	2	3	9	5	8	25
II	4	6	8	4	-	22	1	2	3	9	5	8	25
III	3	6	-	-	8	17	12	3	15	-	-	10	25
IV	8	6	-	-	8	22	12	3	15	-	-	10	25
V	14	-	-	-	-	15	15	10	25	-	-	-	25
VI	25	-	-	-	-	26	15	10	25	-	-	-	25
Total	58*	24	14	8	16	120	56	30	86	18	10	36	150

* (Including Open Course)

Work load (Core)					
Semester	Theory	Lab	Total	Odd Sem Total	Even Sem Total
I	1	2x2	6	58	-
III	12	3x2	18		
V	15	10x2	35		
II	1	2x2	6	-	58
IV	12	3x2	18		
VI	15	10x2	35		

Course	Credit	Semester
Environment Studies	4	1
Disaster Management	4	2
*Human Rights/Intellectual Property Rights/ Consumer Protection	4	3
*Gender Studies/Gerontology	4	4

** Colleges can opt any one of the courses.*

Evaluation of Audit courses:

The examination shall be conducted by the college itself from the Question Bank prepared by the University. The Question paper shall be of 100 marks of 3 hour duration.

Extra credit Activities:

Extra credits are mandatory for the programme. Extra credits will be awarded to students who participate in activities like NCC, NSS and Swatch Bharath. Those students who could not join in any of the above activities have to undergo Calicut University Social Service Programme (CUSSP). Extra credits are not counted for SGPA or CGPA.

Attendance:

A student shall be permitted to appear for the semester examination, only if he/she secures not less than 75% attendance in each semester. Attendance shall be maintained by the Department concerned. Condonation of shortage of attendance to a maximum of 10% in the case of single condonation and 20% in the case of double condonation in a semester shall be granted by University remitting the required fee. Benefits of attendance may be granted to students who attend the approved activities of the college/university with the prior concurrence of the Head of the institution. Participation in such activities may be treated as presence in lieu of their absence on production of participation/attendance certificate (within two weeks) in curricular/extracurricular activities (maximum 9 days in a semester). Students can avail of condonation of shortage of attendance in a maximum of four semesters during the entire programme (Either four single condonations or one double condonation and two single condonations during the entire programme). If a student fails to get 65% attendance, he/she can move to the next semester only if he/she acquires 50% attendance. In that case, a **provisional registration** is needed. Such students can appear for supplementary examination for such semesters after the completion of the programme. Less than 50% attendance requires Readmission. Readmission is permitted only once during the entire programme.

Semester I

Core Course 1

ELE1B01 - Basic Electronics and Network Theorems

Contact Hours per Week: 3 (1T + 2L)

Number of Credits: 2

Number of Contact Hours: 45 Hrs.

Course Outcome

To equip the students with basic components in electronics, identifying and testing them, various measuring and testing instruments, assembling of electronic circuits and basic techniques of troubleshooting.

- To learn the basics of electronic components
- To learn the basics of testing and measuring instruments
- To learn the circuit assembling
- To study circuit troubleshooting

Course Outline

Module I

Introduction to Electronics - Definition, applications, Electric field, Potential, Potential difference, Electric current, Relation between charge and current, Concept of Voltage and Current Sources, AC and DC. Concepts of open and short circuit, Ohm's law, Electrical Resistance, Factors affecting Resistance, Temperature coefficient, Resistivity, Load Resistance and load current, Power dissipation, Passive components –R,C,L- Types, construction, symbols, specifications, Units, Colour coding, Testing.

Module II

Resistance in series and parallel, Kirchhoff's Voltage Law (KVL), Kirchhoff's Current Law (KCL), Principle of Duality, Superposition Theorem. Thevenin's Theorem. Norton's Theorem. Reciprocity Theorem. Maximum Power Transfer Theorem, Two Port Networks: h, y and z parameters.

Module III

Structure of solids –Bonding in solids, Energy bands, Insulators, Conductors, Semiconductors-Semiconductor materials, Intrinsic Semiconductors, Extrinsic Semiconductors –Semiconductor Parameters - Intrinsic concentration, Mobility, Conductivity, Mass action law, Energy gap, Drift and Diffusion Current, Semiconductor Diodes – PN junction, Junction Theory, Depletion layer, Barrier potential, forward and reverse biasing VI characteristics of PN junction diode, Ideal diode, Static and Dynamic Resistance, Diode current equation, Diode notations, diode testing, Special Diodes - Construction, Characteristics and applications of Zener diode, LED.

Module IV

Bipolar Junction Transistors – Types, Construction, Operation, Common Base configuration-input and output characteristics, Common Emitter configuration- input and output characteristics, Common collector configuration, Limits of operation. Field Effect Transistors – introduction, Types, Construction and Characteristics of JFET, Transfer Characteristics, Metal Oxide Semiconductor Field Effect Transistors – Depletion Type, Enhancement Type.
UJT, SCR, – Construction, operation, characteristics and applications.

Text Books

1. NN Bhargava, DC Kulshreshta, SC Gupta “Basic Electronics and Linear Circuits” Tata McGraw-Hill Publishing Company LTD
2. R.S. Sedha “A text book of applied Electronics” S Chand and Company LTD
3. Robert L. Boylestad, Louis Nashelsky “Electronic Devices and Circuit Theory”, 10th edition, Pearson
4. Circuits and Networks – A. Sudhakar, S.P. Shyammoan, TMH Publications

References

1. Jacob millman, Christos c halkias, satyabratajit, 2nd edition “Electronic Devices and circuits”
2. B.L. Theraja, “Electrical and Electronic Engineering”, S Chand and Company LTD
3. R.K. Puri , V.K. Babbar, “Solid state physics and Electronics” , S Chand and Company LTD
4. V.K Mehta, “Principles of Electronics”, S Chand and Company LTD Tata McGraw Hill Education pvt Ltd.
5. S. A. Nasar, Electric Circuits, Schaum’s outline series, Tata McGraw Hill (2004)
6. Electrical Circuits, M. Nahvi and J. Edminister, Schaum’s Outline Series, Tata McGraw-Hill. (2005)

Structure of Question Paper

The External question paper is of 2 hours duration with 60 marks. Question paper shall consist of three sections. Section A contains 12 short answer type questions of 2 marks each, and the candidate can score a maximum of 20 marks. Section B contains 7 paragraph / problem type questions of 5 marks each and the candidate can score a maximum of 30 marks. Section C contains 2 essay type questions of 10 marks each of which candidates has to answer 1 question and can score a maximum of 10 mark. Questions must be distributed uniformly covering all modules.

Core Lab1 1

ELE2B03 – Basic Electronics and Network Theorems Lab

Contact Hours per Week: 2 (2L)

Number of Credits: 2

Number of Contact Hours: 30 Hrs.

List of experiments:

1. Familiarization of various measuring and testing equipment and power sources – Voltmeter, Ammeter, Multimeter, LCR meter, CRO, Function Generator, etc.
2. Familiarization and testing of passive and active components.
3. Verification of equivalent resistance of series and parallel resistor networks, Voltage division and Current division Rules
4. Verification of KVL and KCL
5. Diode Characteristics (Si, Ge, LED and Zener)
6. Common base transistor characteristics
7. Common emitter transistor characteristics
8. FET characteristics
9. UJT characteristics
10. SCR characteristics

References

1. NN Bhargava, DC Kulshreshta, SC Gupta “Basic Electronics and Linear Circuits”, Tata McGraw-Hill Publishing Company LTD
2. Jacob millman, Christos c halkias, satyabratajit , 2nd edition “Electronic Devices and Circuits”, Tata McGraw Hill Education pvt Ltd.

Semester II

Core Course 2

ELE2B02- Electronic Circuits

Contact Hours per Week: 3 (1T + 2L)

Number of Credits: 2

Number of Contact Hours: 45 Hrs.

Course Outcome

To equip the students with basic components in electronics, identifying and testing them, various measuring and testing instruments, assembling of electronic circuits and basic techniques of troubleshooting.

- To learn fundamentals of electronics
- To learn the circuit assembling
- To study circuit troubleshooting

Course Outline

Module I

Rectifiers – Half wave, full wave, bridge – average value, RMS value, PIV, Ripple factor, efficiency, Comparison of rectifiers. Filters - C, L, LC, π . Regulators – Zener diode voltage Regulator, Series voltage Regulator, fixed voltage dc power supply circuit, Line and Load Regulation. Wave shaping Circuits -Clipping circuits – Positive, Negative, Biased, Combination. Clamping Circuits – Positive, Negative, Biased, Combination. RC Integrator and Low Pass Filter, RC Differentiator and High Pass Filter.

Module II

Transistor Biasing – operating point, DC Load Line, Fixed bias, Emitter bias, Voltage Divider bias, Collector feedback, Emitter follower, bias stabilization, BJT AC Analysis – Amplification in the ac domain, BJT modeling, The Hybrid equivalent model – Amplifier analysis, cascaded system, RC coupled BJT amplifier, tuned amplifier.

Module III

Frequency Response –Logarithm, decibel, general frequency consideration, gain bandwidth product, Concept of power amplifiers – class A, class B, class C – operation – types of distortions in power amplifiers, Complementary Symmetry Push-Pull Amplifier. Feedback - Concepts, types, effect on

gain, input impedance, output impedance, frequency distortion, noise, nonlinear distortion, bandwidth and gain stability.

Module IV

Sinusoidal Oscillators –Criteria for oscillations - Barkhausen-oscillator operations, phase shift oscillator, Wien bridge oscillator, Colpitts oscillator, Hartley oscillator, crystal oscillators, non-sinusoidal oscillators –classification, transistor as a switch, astable, monostable and bistable multivibrators, Schmitt trigger.

Text Books

1. Bhargava, Kurukshetra &Gupta, "Basic Electronics and Linear Circuits", Tata McGraw- Hill Publishing LTD.
2. R S Sedha, "Applied Electronics", S.Chand and Company LTD.
3. Boylestad, Louis Nashelsky "Electronic Devices and Circuit Theory", 10th edition, Pearson

References

1. Jacob Millman, Christos c Halkias, satyabratajit , 2nd edition "Electronic Devices and circuits", Tata McGraw Hill Education pvt Ltd.
2. V.K Mehta, "Principles of Electronics", S Chand and Company LTD
3. Jacob Millman & Halkias "Integrated Electronics", Tata McGraw Hill 2009

Structure of Question Paper

The External question paper is of 2 hours duration with 60 marks. Question paper shall consist of three sections. Section A contains 12 short answer type questions of 2 marks each, and the candidate can score a maximum of 20 marks. Section B contains 7 paragraph / problem type questions of 5 marks each and the candidate can score a maximum of 30 marks. Section C contains 2 essay type questions of 10 marks each of which candidates has to answer 1 question and can score a maximum of 10 mark. Questions must be distributed uniformly covering all modules.

Core Lab 2

ELE2B04- Electronic Circuits Lab

Contact Hours per Week: 2 (2L)

Number of Credits: 2

Number of Contact Hours: 30 Hrs.

List of experiments:

1. Rectifier circuits: Half Wave, Centre tapped and Bridge
2. Different Filter circuits (C, L, pi)
3. Zener Voltage Regulator
4. Diode clippers and Clampers
5. RC differentiator and HPF
6. RC Integrator and LPF
7. Voltage divider biasing circuits
7. Single stage transistor amplifier
8. RC Phase Shift Oscillator
9. Crystal Oscillators
10. Astable Multivibrator and Monostable multivibrator using BJT

References

1. NN Bhargava, DC Kulshreshta, SC Gupta “Basic Electronics and Linear Circuits”
Tata McGraw-Hill Publishing Company LTD
2. Jacob millman, Christos c halkias, satyabratajit , 2nd edition “Electronic Devices and circuits”, Tata McGraw Hill Education pvt Ltd.

Semester III

General Course 1

XXXXA11 – Python Programming

Contact Hours per Week: 4

Number of Credits: 4

Number of Contact Hours: 60 Hrs.

Course Outcomes

- Understand various statements, data types and functions in Python
- Develop programs in Python programming language
- To learn different features of Python language

Course Outline

Module I

Introduction to python, features, IDLE, python interpreter, Writing and executing python scripts, comments, identifiers, keywords, variables, data type, operators, operator precedence and associativity, statements, expressions, user inputs, type function, eval function, print function.

Module II

Boolean expressions, Simple if statement, if-elif-else statement, compound Boolean expressions, nesting, multi way decisions. Loops: The while statement, range functions, the For statement, nested loops, break and continue statements, infinite loops.

Module III

Functions, built-in functions, mathematical functions, date time functions, random numbers, writing user defined functions, composition of functions, parameter and arguments, default parameters, function calls, return statement, using global variables, recursion.

Module IV

String and string operations, List- creating list, accessing, updating and deleting elements from a list, basic list operations. Tuple- creating and accessing tuples in python, basic tuple operations. Dictionary, built in methods to access, update and delete dictionary values. Set and basic operations on a set.

References:

1. E. Balaguruswamy, Introduction to Computing and Problem Solving Using Python
2. Richard L. Halterman, Learning To Program With Python
3. Martin C. Brown, Python: The Complete Reference

General Course II

XXXXA12 – Sensors and Transducers

(Basic principle, working and applications only expected)

Contact Hours per Week: 4

Number of Credits: 4

Number of Contact Hours: 60 Hrs.

Course Outcomes

The students will be able to

- Explain resistance, inductance and capacitance transducers.
- Perceive the concepts of temperature transducers.
- Perceive the concepts of level transducers and pressure transducers
- Explain flow transducers, electromagnetic transducers, radiation sensors and sound transducers

Course Outline

Module I

Transducers: Definition, Principle of sensing & transduction, Classification, Characteristics of transducers.

Resistance Transducer: Basic principle – Potentiometer –Loading effects, Resistance strain gauge–Types.

Inductance Transducer: - Basic principle – Linear variable differential transformer – Types.

Capacitance Transducer: Basic principle- transducers using change in area of plates – distance between plates- variation of dielectric constants –Types

Module II

Thermal sensors: Resistance change type: RTD - materials, types, working principle, Thermistor - materials, working principle. Thermo emf sensors: Thermocouple – Principle and types. IR Radiation sensors: Principle and types

Module III

Pressure Transducers: basic principle- different types of manometers-u tube manometer-well type manometers.

Level transducer-continuous level measurement-discrete level measurement-mass –capacitive level gauges

Module IV

Flow Transducers: Bernoulli's principle and continuity, Orifice plate, nozzle plate, venture tube, Rotameter, anemometers, electromagnetic flow meter.

Radiation sensors: LDR, Photovoltaic cells, photodiodes, photo emissive cell types

Sound Transducers: Sound level meter, Microphone.

Hall Effect transducers

Text Books:

1. D Patranabis, Sensors and Transducers, PHI, 2nd Edition.
2. Murthy D.V.S., —Transducers and Instrumentation, 2nd Edition, Prentice Hall of India Private Limited, New Delhi, 2010.

Reference Books:

1. E. A. Doebelin, Measurement Systems: Application and Design McGraw Hill, New York
2. A.K. Sawhney,- A course in Electrical & Electronic Measurement and Instrumentation, Dhanpat Rai and Company Private Limited.
3. S.Renganathan, —Transducer Engineering, Allied Publishers, 2005

Core Course 3

ELE3B05- Digital Electronics

Contact Hours per Week: 7 (4T + 3L)

Number of Credits: 3

Number of Contact Hours: 60 Hrs.

Course Outcome

To equip the students with detailed knowledge in digital electronics, digital IC's in the 74XX Series. Many of the ideas are important to learn microprocessors.

To learn different number systems, logic gates, comparators, flip flops etc

Course Outline

Module I

Number systems – Decimal, Binary, Octal & Hexadecimal – conversions, Digital codes – BCD, Excess 3, Gray code-conversions, ASCII codes, Boolean algebra & theorems, SOP & POS, De Morgan's theorem, Simplification of Boolean expressions using Boolean Algebra & K Map (upto four variables). Logic gates – AND, OR, NOT, NAND, NOR, XOR, XNOR. Universal Properties of NAND and NOR.

Module II

Different Logic families: TTL, CMOS, ECL, Open Collector & its characteristics. Combinational circuits: Adders - Half adder and Full adder. Subtractors - Half and Full subtractor. Comparators - 1 bit magnitude & 2 bit magnitude. Decoders - 2 to 4 & 3 to 8. Encoders - Octal to Binary & Decimal to BCD, Code converters - Gray to Binary, Binary to Gray and Binary to BCD.

Module III

Multiplexers: 2 input, 4 input & 8 input. Demultiplexers: 1 to 4 & 1 to 8. Realization of Boolean expression using multiplexers and demultiplexers. Familiarization of popular ICs: 7483 (4 –Bit Binary Adder), 74151(Multiplexer), 74154(De- Multiplexer) and its applications. Sequential circuits: Flip Flops: RS latch, clocked RS, D, JK, T, Preset and Clear operations, Race-around condition in JK Flip-Flop, Master slave JK. Applications – Latches, Shift registers - SISO, SIPO, PISO, PIPO, typical circuits & applications as Ring counter and Johnson counter.

Module IV

Counters: State diagram & State table. Asynchronous counters: Concepts and Design of 2bit & 4 bit Up/Down counter, MOD counter. Synchronous counters, Familiarization of popular ICs: 7490 (Decade Counter), 4017 (Decade Counter/Divider with 10 Decoded Outputs) and 7446 (BCD to Seven Segment Decoder).

Converters: ADC – Flash, Successive Approximation, Counter Ramp. DAC-Weighted Resistor and R-2R Ladder. Parameters of DAC and ADC.

Text Books

1. Digital fundamentals - Thomas Floyd
2. Anand Kumar, Fundamentals of digital circuits, PHI, 2/e, 2012.
3. Digital Principles - Malvino

References

1. John M Yarbrough, Digital logic- Application and Design, Thomson Learning, 2006.
2. John Wakerly, Digital Design Principles and Practice, Pearson, 4/e, 2012.
3. Morris Mano, Ciletti, Digital Design, 4/e, Pearson, 4/e, 2009
4. Digital Integrated circuits - Taub and Schilling

Structure of Question Paper

The External question paper is of 2 hours duration with 60 marks. Question paper shall consist of three sections. Section A contains 12 short answer type questions of 2 marks each, and the candidate can score a maximum of 20 marks. Section B contains 7 paragraph / problem type questions of 5 marks each and the candidate can score a maximum of 30 marks. Section C contains 2 essay type questions of 10 marks each of which candidates has to answer 1 question and can score a maximum of 10 mark. Questions must be distributed uniformly covering all modules.

Core Lab 3

ELE4B07- Digital Electronics Lab

Contact Hours per Week: 2 (2L)

Number of Credits: 2

Number of Contact Hours: 30 Hrs.

List of experiments:

3. Logic gates
 - To verify the truth tables of NOT, AND, OR and XOR gates
 - To verify Demorgan's theorem for two variables
 - Realization of SOP and POS expressions using Basic logic gates
3. Universal Gates

- To verify the truth tables of NAND and NOR gates
 - To verify the universal properties of NAND and NOR gates
 - Realization of SOP and POS expressions using NAND and NOR gates
4. Adders
 - To realize half adder and Full adder circuits and verify the truth tables
 - To verify the operation of 7483 four bit parallel adder
 5. Subtractors
 - To realize half subtractor and Full subtractor circuits and verify the truth tables
 - To construct and verify four bit subtractor using IC 7483
 6. Comparators
 - To design and verify two bit magnitude comparator using gates
 - To verify the operation of 4 bit magnitude comparator IC 7485
 7. Multiplexers
 - To verify the truth table of 4 to 1 multiplexer using IC 74153
 - To verify the truth table of 8 to 1 multiplexer using IC 74151
 - To realize a Boolean function (up to 3 variable) using multiplexer IC 74153/74151
 8. De-Multiplexers and Decoders
 - To design 1 to 8 De multiplexer using IC 74138
 - To design 3 to 8 decoder using IC 74138
 - To study the operation of 4 line to 16 line Decoder / De-multiplexer IC 74154
 - To study the operation of seven segment decoder ICs
 - To realize Boolean Expressions using decoders
 9. Encoders
 - To realize 4 to 2 line encoder and verify its truth table
 - To verify the operation of priority encoder IC 74148
 10. Latches and Flip Flops
 - To realize RS latch using gates
 - To design and verify the operation of Clocked RS flip flop using NAND gates (7400)
 - To realize JK flip flop using NAND gates (7410 and 7400)
 - To verify the operation of D flip flop IC7474 and JK flip flop IC 7476
 11. Counters
 - To design and construct asynchronous decade counter using JK flip flops
 - To design and construct synchronous decade counter using JK flip flops
 - To design and verify the operation of counter IC 7490 as MOD 2 Counter, MOD 5 Counter, MOD 8 Counter, MOD 10 Counter
 12. Shift Registers
 - To design and verify the operation of 4 bit SISO,SIPO, PISO and PIPO shift registers using D flip flop
 13. Shift Register Counters
 - To design and verify the operation of 4bit Ring counter using D flip flops
 - To design and verify the operation of 4bit Johnson counter using D flip flops

** Pin out diagrams will be provided during Lab examination.*

Core Lab 5

Skill Development Lab 1

Contact Hours per Week: 1 (1L)

Number of Contact Hours: 15 Hrs.

List of experiments:

1. Simulation and PCB design using software (Minimum Two Experiment)
 - Rectifier and Filter Circuits
 - RC Amplifier Circuit
 - Oscillator Circuits
 - Combinational Circuits
 - Counters using flip flops
 - Shift Registers
2. PCB fabrication - any one circuit
3. Assembling, Soldering and testing of the PCB fabricated circuit

Guidelines:

1. Student may use any software like SPICE, e-Sim, Kicad, Orcad, Proteus etc.
2. A printed record of laboratory work with schematics, simulation results and PCB layout as print out must be submitted along with the report of Skill Development Lab.
3. Evaluation will be done at the end of 4th semester.

Semester IV

General Course III

XXXXA13 – Data Communication & Optical Fibers

Contact Hours per Week: 4

Number of Credits: 4

Number of Contact Hours: 45 Hrs.

Course Outline

Module I

Introduction- Components, Networks, Protocols and standards, Basic Concepts: Line Configuration, Topology Transmission mode, analog and digital signals, Encoding and modulating- analog-to-digital conversion, digital to analog conversion, digital data transmission, DTE-DCE interface, modems, cable modems. Transmission media: guided media, unguided media, and transmission impairment.

Module II

Multiplexing: Many to one, one to many, frequency division multiplexing, wave division multiplexing, TDM, multiplexing applications: the telephone system, Cellular system, Mobile communication- GSM, Mobile services, GSM system Architecture, Radio interface in GSM

Module III

Data link Control: Line Discipline, flow control, error control, Data link Protocols: Asynchronous Protocols, synchronous protocols, character oriented protocols, bit – oriented protocols, link access procedures. Local Area Networks: Ethernet, token bus, token ring, FDDI, Comparison, Switching-circuit switching, packet switching, message switching, integrated services digital networks (ISDN): services, history, subscriber access to ISDN.

Module IV

(Derivation is not required)

Overview Of Optical Fiber Communication - Introduction, historical development, general system, advantages, disadvantages, and applications of optical fiber communication, optical fiber waveguides, fiber materials, Optical Sources And Detectors- Introduction, LED's, LASER diodes, Photo detectors. Ray theory, cylindrical fiber, single mode fiber, cutoff wave length, mode field diameter.

Text Book

1. Behrouz A. Forouzan, Data Communication and Networking, TMH

2. Mobile Communications- Jochen H.Schiller, Second Edition, Pearson.
3. Optical Fiber Communication – Gerd Keiser, 4th Ed., MGH, 2008.

Reference Books:

1. William Stallings: Data & Computer Communications, 6/e, Pearson Education.
2. William L. Schweber : Data Communication, McGraw Hill.
3. Electronic Communication Systems - Kennedy and Davis, TMH
4. Optical Fiber Communications– – John M. Senior, Pearson Education. 3rd Impression, 2007.
5. Fiber optic communication – Joseph C Palais: 4th Edition, Pearson Education

General Course IV

XXXXA14 – Microprocessors – Architecture and Programming

Contact Hours per Week: 4
Number of Credits: 4
Number of Contact Hours: 45 Hrs.

Course Outline

Module I

General architecture of computer, Introduction to Microprocessor, Memory classification, Introduction to 8085, Microprocessor bus organizations, data bus, address bus, control bus. Memory addressing, memory mapping. 8085 architecture in detail. General purpose registers and special purpose registers, flag register -8085 pins and signals.

Module II

Assembly language programming basics. Opcode, Mnemonics etc. 8085 instruction set, Data transfer, Arithmetic and Logic, Shifting and rotating, Branching/Jump, Program control. Addressing modes, Memory read and write cycle. Timing diagram, Instruction cycle, machine cycle and T-states. Types of I/O addressing, simple programs.

Module III

Types of programming techniques looping, indexing (pointers), delay generation. Stack in 8085, call and return Instructions. Data transfer between stack and microprocessor. Subroutine and delay

programs. Interrupts in 8085. Interrupt driven programs. Interfacing - Programmable peripheral devices - 8255A, 8254, 8237.

Module IV

Introduction to 8086/88 microprocessors – overview, 8086 internal architecture. The execution unit, BIU, Registers, Flags, Segmentation, physical address calculation and addressing modes.

Text Book

1. Ramesh S. Gaonkar, Microprocessor Architecture Programming and Application with 8085, Prentice Hall
2. Doughles V Hall, Microprocessors and Interfacing: Programming and Hardware, Tata McGraw Hill

Reference Book

1. Microprocessor and Microcomputer - Based system Design - M. Rafiquzzman - CRC press
2. A.P Mathur, Introduction to Microprocessors, Tata McGraw-Hill Education
3. The Intel Microprocessors: 8086/8088, 80186/80188, 80286, 80386, 80486, Pentium, Pentium Pro, Pentium II, III, IV and Core 2 with 64 bit Extensions, Barry B. Brey, Prentice Hall Pearson
4. Microprocessors PC Hardware and Interfacing –N.Mathivanan – PHI

Core Course 4

ELE4B06 - Analog Integrated Circuits

Contact Hours per Week: 7 (4T + 3L)

Number of Credits: 3

Number of Contact Hours: 60 Hrs.

Course Outcome

To equip the students with detailed knowledge of Analog IC's like OPAMP 741, IC 555 etc.

To learn the basics of Amplifiers, filters, wave form generators, comparators, Multivibrators and voltage regulators

Course Outline

Module I

Block Diagram of typical operational Amplifiers – Ideal Op-amp characteristics – Op amp Parameters – Inverting and Non-Inverting Amplifier – Voltage Follower- Summing Amplifier-

Differential Amplifier- Instrumentation Amplifier – V to I and I to V converter- Integrator – Differentiator – Typical circuits – Applications.

Module II

Introduction – First order – Butter worth – Low pass, High pass, Band pass, Band Reject, Notch and All pass Filters – Typical circuits- Applications. Wave form generators – Square wave generator- Triangular and Sawtooth wave generators – sine wave oscillators (Phase shift, Wien Bridge and Quadrature Oscillators).

Module III

Basic comparator – Characteristics – Typical comparator circuits using op amp – zero crossing detector – Schmitt trigger – Typical Circuits – Operation – Application-Window detector-Peak detector-Sample and Hold circuit-Clippers and Clampers-half wave Rectifier – Precision Rectifier. Introduction to Timer 555 -Monostable and Astable Multivibrator -Application of Monostable and Astable Multivibrator

Module IV

Voltage controlled oscillator (VCO), PLL – block diagram, Operating principle, parameters, pinout, function, applications and typical circuits. Basic circuit configuration and characteristics of voltage regulators – Basic blocks of linear voltage regulator – three terminal fixed regulators (78XX and 79XX), Adjustable Positive voltage Regulator(LM 317) and Adjustable Negative voltage Regulator(LM 337)- variable voltage Regulators (723), Switching regulator, S.M.P.S – Typical circuits (Buck and Boost)–Applications.

Text book

1. Ramakant A. Gayakwad ,”Op-amp and Linear ICs”, Prentice-Hall of India Private LTD.
2. Botkar,” Integrated Circuits”

Reference

1. Mottershed,” Electronic Devices and circuits”,
2. Millman & Halkias,”Integrated Electronic”, Tata McGraw-Hill Publishing LTD.
3. Tobey & Buelsman ,”Op-amp Design and Application”,

Structure of Question Paper

The External question paper is of 2 hours duration with 60 marks. Question paper shall consist of three sections. Section A contains 12 short answer type questions of 2 marks each, and the candidate can score a maximum of 20 marks. Section B contains 7 paragraph / problem type questions of 5 marks each and the candidate can score a maximum of 30 marks. Section C contains 2 essay type questions of 10 marks each of which candidates has to answer 1 question and can score a maximum of 10 mark. Questions must be distributed uniformly covering all modules.

Core Lab 4

ELE4B08 - Analog Integrated Circuits Lab

Contact Hours per Week: 2 (2L)

Number of Credits: 2

Number of Contact Hours: 30 Hrs.

List of experiments:

1. Inverting and non-inverting op-amp configuration and its characteristics.
2. Differentiator and integrator circuit characteristics.
3. Summing and difference amplifiers.
4. Voltage follower and instrumentation amplifier.
5. Low pass and High pass filters and their frequency response.
6. Band pass filter and Band rejection filter and their frequency response.
7. Schmitt trigger-measurement of UTP and LTP.
8. Triangle wave generator.
9. Astable and monostable multivibrator using 555
10. IC fixed voltage regulation and characteristics.
11. IC 723 variable voltage regulator.
12. Oscillators: 1) Wein bridge 2) RC phase shift.

Text book:

1. T.D. Kuryachan & Shyam Mohan S, "Electronics Lab Manual, Vol.II", Ayodhya Publications.

Core Lab 5

ELE4B09- Skill Development Lab

Contact Hours per Week: 1 (1L)

Number of Credits: 1

Number of Contact Hours: 15 Hrs.

Design and Development of a mini project based on Skill Development Lab 1 and Core Courses 1-4

Guidelines:

1. Students should select a problem which addresses some basic home, office or other real life applications.
3. The electronic circuit for the selected problem should have at least 8 to 15 components.
4. Students should understand testing of various components.
5. Soldering of components should be carried out by students.

6. Students should develop a necessary PCB for the circuit.
7. Students should see that final circuit submitted by them is in working condition.
8. 5 - 10 pages report to be submitted by students.
9. Group of maximum two students can be permitted to work on a single mini project.
10. The mini project must be hardware based. The software and firmware are not allowed.
11. Department may arrange demonstration with poster presentation of all mini projects developed by the students at the end of 4th semester.

Semester V

Core Course 5

ELE5B10 - Electromagnetic Theory

Contact Hours per Week: 4 (4T)

Number of Credits: 4

Number of Contact Hours: 60 Hrs.

Course Outcome

To equip the students with basic knowledge in Electromagnetic Theory, which is important in the field of communications?

To learn the Electrostatics, Magneto statics and Electrodynamics

Course Outline

Module I: Fundamental of Vector Analysis

Fundamental vector operations, Coordinate systems-unit length, area and volume, Integrals of vector functions, Gradient of a scalar field, Divergence of a vector field, Divergence theorem, Curl of a vector field, Stokes's theorem, Physical Interpretation of Gradient, divergent and curl, coordinate transformations.

Module II: Electrostatics

Static Electric Fields; Postulates of electrostatics, Coulomb's law, Gauss's law and applications, Electric potential, dielectrics, flux, boundary conditions, capacitance, capacitors, Electrostatic energy and forces, Solution of Electrostatic Problems- Poisson's and Laplace's equations-Method of images, Boundary conditions and Boundary value problems.

Module III: Magnetostatics

Steady Electric Currents; current density, Ohm's law, Boundary condition for current density, Equation of continuity and Kirchhoff's law, Biot-Savart Law, Postulates of Magnetostatics, Vector Magnetic Potential, Force between two current wires, Ampere's Circuit Theorem, Magnetic dipole, Boundary conditions for magnetostatic fields, Magnetic energy, Magnetic forces and torques.

Module IV: Time varying Electromagnetic fields and waves

Faraday's law of electromagnetic induction, Inconsistency of Amperes law, Maxwell's equations , Integral and differential forms, conduction current and displacement current- Uniform Plane waves- Poynting theorem and Poynting vector- Solution for free space condition-Intrinsic impedance- wave equation for conducting medium- Wave polarization, Reflection and transmission, TE, TM and TEM waves, fundamentals of antennas and parameters.

Text Books

1. Engineering Electromagnetics – Haytt (McGraw-Hill Education)
2. Elements of Electromagnetics--Matthew N. O. Sadiku (Oxford University Press)
3. Electromagnetic Field Theory and Transmission Lines--G. S. N. Raju (Pearson Education)

Structure of Question Paper

The External question paper is of 2.5 hours duration with 80 marks. Question paper shall consist of three sections. Section A contains 15 short answer type questions of 2 marks each spanning the entire syllabus and the candidate can score a maximum of 25 marks. Section B contains 8 paragraph / problem type questions of 5 marks each; two questions from each module (2 quest. x 4 module = 8 quest.), and the candidate can score a maximum of 35 marks. Section C contains 4 essay type questions of 10 marks each; one from each module, of which candidate has to answer 2.

Core Course 6

ELE5B11 - Microcontroller & Interfacing

Contact Hours per Week: 8 (5T + 3L)

Number of Credits: 3

Number of Contact Hours: 75 Hrs.

Course Outcome

To equip the students with basic understanding of Microcontrollers and its applications.
To learn the basics of microcontrollers

Course Outline

Module I

Comparison between microprocessor and Microcontroller .The 8051 Microcontroller .Architecture of 8051 microcontroller. Internal memory (ROM) organization. Important Registers .Internal RAM organization. Register banks, Byte and bit addressable area. Flags and flag register (PSW) .Program counter and data pointer. Stack and Stack pointer. Special Function Registers. 8051 Ports and I/O pins, control signals. External memory interfacing signals.

Module II

8051 instruction set, Data transfer (internal and external), Arithmetic and Logic, Shifting and rotating, Branching/Jump. Bit related instructions and operations. Addressing modes. External memory related instruction. Stack and subroutine. Call and return instructions. Push and Pop instructions. Delay generation, calculation and programs.8051 Interrupts.

Module III

Counters and Timers: Timer / counter interrupt – Delay using Timer - Modes of Operation - Counting .RS232 Communication standard. Serial data input of serial data output : Serial data interrupt - Data transmission Data reception - serial data transmission interrupts : Times Flag interrupt - Serial port interrupt - External interrupt - Reset - Interrupt concept - interrupt priority - interrupt destination - software generated interrupts.

Module IV

Introduction to Arduino - Pin configuration arduino uno and architecture, Device and platform features, Concept of digital and analog ports.

Introduction to Embedded C and Arduino IDE -Arduino data types, Variables and constants, Operators, Control Statements, Arrays, Functions. Input Output - Pins Configuration, Pull-up Resistors, Functions - pinMode() , digitalWrite() , analogRead() , analogWrite() and Arduino Interrupts. Time Functions - delay (), delayMicroseconds (), millis (), micros ().

Interfacing -UART, Serial monitor. Interfacing a 8 bit LCD to Arduino, Arduino LCD Library, Humidity Sensor, Temperature Sensor (LM35), Water Detector / Sensor, PIR Sensor, Ultrasonic Sensor.

Text Book:

1. The 8051 microcontroller and embedded systems using assembly and C - Kenneth.J.Ayala - CENGAGE Learning.
2. The 8051 microcontroller and applications – Ali Mazidi
3. Microprocessors and micro-controllers (8085, 8051) – Krishna Kant -PHI India
4. Arduino For Dummies by John Nussey
5. Arduino-Based Embedded Systems: By Rajesh Singh, Anita Gehlot, Bhupendra Singh, and Sushabhan Choudhury.
6. Arduino Made Simple by Ashwin Pajankar
7. <https://www.arduino.cc>

Structure of Question Paper

The External question paper is of 2 hours duration with 60 marks. Question paper shall consist of three sections. Section A contains 12 short answer type questions of 2 marks each, and the candidate can score a maximum of 20 marks. Section B contains 7 paragraph / problem type questions of 5 marks each and the candidate can score a maximum of 30 marks. Section C contains 2 essay type questions of 10 marks each of which candidates has to answer 1 question and can score a maximum of 10 mark. Questions must be distributed uniformly covering all modules.

Core Course 7

ELE5B12 - Network Theory

Contact Hours per Week: 4 (4T)

Number of Credits: 4

Number of Contact Hours: 45 Hrs.

Course Outcome

To equip the students with basic knowledge in the Network theory
To learn the basics of Networks, Fourier series, Network theorems

Course Outline

Module 1

Basic circuit elements and waveforms - introduction - circuit components - assumption of circuit analysis - sources of electrical energy - standard input signals - sinusoidal signals parallel and series parallel networks - source transformation - Mesh and nodal analysis, Star-Delta Conversion, network equation for RLC network -magnetic coupling.

Module 2

DC Transient Analysis: Initially charged RC circuit, RL circuit with initial current, time constant, RL and RC circuits with sources, DC response of series RLC circuits (using differential equations).

Module 3

AC Circuit Analysis: Sinusoidal Voltage and Current, Definition of Instantaneous, Peak, Peak to Peak, Root Mean Square and Average Values. Voltage-Current relationship in Resistor, Inductor and Capacitor, Phasor, Complex Impedance, Power in AC Circuits: Instantaneous Power, Average Power, Reactive Power, Power Factor. Sinusoidal Circuit Analysis for RL, RC and RLC Circuits

Module 4

Resonance in Series and Parallel RLC Circuits, Frequency Response of Series and Parallel RLC Circuits, Quality (Q) Factor and Bandwidth. Passive Filters: Low Pass, High Pass, Band Pass and Band Stop.

Text Books

1. Roy Choudhary, Networks and Systems, New Age International
2. Sudhakar and Shyam Mohan, Circuits and Networks- Analysis and Synthesis, TMH
3. W. H. Hayt, J. E. Kemmerly, S. M. Durbin, Engineering Circuit Analysis, Tata McGraw Hill
4. Electrical Circuits, M. Nahvi and J. Edminister, Schaum's Outline Series, Tata McGraw-Hill
5. S. A. Nasar, Electric Circuits, Schaum's outline series, Tata McGraw Hill (2004)
6. Alexander and M. Sadiku, Fundamentals of Electric Circuits, McGraw Hill (2008)

References

1. Van Valkenburg, Network Analysis, PHI, 3/e, 2011
2. Franklin F. Kuo, Network Analysis and Synthesis, Wiley India, 2/e, 2012
3. Robert L. Boylestad, Essentials of Circuit Analysis, Pearson Education (2004)

Structure of Question Paper

The External question paper is of 2.5 hours duration with 80 marks. Question paper shall consist of three sections. Section A contains 15 short answer type questions of 2 marks each spanning the entire syllabus and the candidate can score a maximum of 25 marks. Section B contains 8 paragraph / problem type questions of 5 marks each; two questions from each module (2 quest. x 4 module = 8 quest.), and the candidate can score a maximum of 35 marks. Section C contains 4 essay type questions of 10 marks each; one from each module, of which candidate has to answer 2.

Core Lab 6

ELE6B17 - Microprocessor & Microcontroller programming and interfacing lab (8085, raspberry pi, 8051 and Arduino)

Number of Credits: 3

PART A – Microprocessor and Interfacing Lab

Contact Hours per Week: 3 (3L)

Number of Contact Hours: 45 Hrs.

Section A (Microprocessor 8085)

List of experiments:

1. Addition – 8 bit, 16 bit
2. Subtraction – 8 bit, 16 bit
3. Block data transfer
4. Array addition (multibyte)
5. Logical operators – AND, OR NOT
6. Multiplication & Division
7. Decimal to ASCII and ASCII to Decimal
8. Decimal to Hexa and Hexa to Decimal
9. Ascending Order & Descending order
10. Largest & smallest
11. Interfacing with LED's
12. square wave Generation

Section B (Python Programming with Raspberry Pi)

List of experiments:

1. Interfacing LED
2. Relay Interfacing
3. Temperature monitoring
4. IR interfacing
5. Water level controller
6. Moisture sensing

PART B – Microcontroller and Interfacing Lab

Contact Hours per Week: 3 (3L)

Number of Contact Hours: 45 Hrs.

List of experiments:

8051:

1. Addition – 8 bit, 16 bit.
2. Subtraction – 8 bit, 16 bit.
3. Multiplication & Division
4. Array addition (multibyte)
5. Logical Operations – AND, OR, NOT
6. Decimal to ASCII and ASCII to Decimal.
7. Decimal to Hexa and Hexa to Decimal.
8. Interfacing with LED's

Arduino:

9. Familiarization of Arduino IDE
10. Interfacing LEDs and Switches
11. Traffic Light Controller
12. Automatic Guided Vehicle
13. Water Level Controller using float sensors
14. Interfacing LCD
15. Digital Thermometer using IC LM35
16. Distance Measurement using Ultrasonic Sensor
17. LED brightness control using PWM

- Opcode sheet will be provided during Lab examination.

Industrial Visit

Course Outcome:

- To get an exposure to research and developments (R&D) activities in the electronics, real workstations, plants, machines, etc.
- Make students aware of practical application of instruments handled during course curriculum.
- To interact with technical or administrative experts of the organization/ Institutions.
- Make Students Aware with Industry Practices and career opportunities.
- Acquaint Students with Interesting Facts and Newer Technologies to generate new entrepreneurs.

Guide Lines:

- Minimum one days visit to National research Institutes, Laboratories, places of scientific importance, Industries or plants.
- OR one week Industrial Training / internship at any industry.
- The Industrial visit should complete with in the fifth semester.
- A 10 – 20 page Industrial visit / Training report have to be submitted with certificate from industry / institute, sufficient photos and analysis along with Project for evaluation in the sixth semester.
- Industrial visit report must be certified by the tour coordinator and head of the department and that are only considered for final evaluation.
- Evaluation of industrial visit is solely based on report submitted without any oral examination.

Distribution of Marks (External Evaluation)

Sl. No.	Item	Mark (%)
1	Report	50%
2	Analysis	25%
3	Photos (minimum 5 photos)	25%

- *There is no internal evaluation for industrial visit*

Project Work

Contact Hours per Week: 4 (4L)

Number of Contact Hours: 60 Hrs.

Course Outcome:

- To apply knowledge acquired through curriculum in practical problem solving
- To develop creative thinking in finding viable solutions to real life problems
- To foster innovation in design of products, processes or systems

Guide Lines

- Project work is for duration of two semesters and is expected to be completed in the sixth semester.
- Each student group consisting of not more than four members is expected to design and develop a complete system addressing a real life problem in the relevant area.
- The project may be implemented using only hardware, or a combination of both hardware and software.
- Project monitoring committee consisting of the guide and other faculties of the department.
- Each project group should submit project synopsis within five weeks (20 project Hours) from start of fifth semester to the project monitoring committee.
- Project monitoring committee shall study the feasibility of each project work before giving consent.
- Each project group should maintain a log book of activities of the project. It should have entries related to the work done, problems faced, solution evolved etc.
- Literature survey is to be completed in the fifth semester.
- Students should execute the project work using the facilities of the institute. However, external projects can be taken up in reputed industries or institutes, if that work solves a technical problem of the external firm. Prior sanction should be obtained from the head of department before taking up external project work and there must be an internal guide for such projects.
- Each student has to submit an interim report of the project at the end of the 5th semester.
- Members of the group will present the project details and progress of the project before the committee at the end of the 5th semester.
- 50% of the internal Mark is evaluated and published on the notice board at the end of 5th semester.

Semester VI

Core Course 8

ELE6B13 - Communication System

Contact Hours per Week: 7 (4T + 3L)

Number of Credits: 4

Number of Contact Hours: 60 Hrs.

Course Outcome

To equip the students with basic knowledge in Communication systems

To learn the basics of modulation basics of AM, FM, and PCM

To learn the Digital modulation techniques

Course Outline

Module I

Communication Systems- Modulation – Need for modulation, Amplitude Modulation- Frequency spectrum of AM wave – Representation of AM wave, Power relation in AM wave, Generation of AM- DSBSC- Balanced Modulator, SSB Techniques – Filter system, Phase shift method, Third method.

Module II

Frequency Modulation – Theory of Frequency and Phase modulation, Mathematical representation of FM, FM-Noise Triangle, De-emphasis, Pre-emphasis, Comparison of Wide band and Narrow band FM, FM Generation and Detection-Generation of FM – Direct method, Indirect method, discriminator circuits.

Module III

Radio receivers- Receiver types, TRF, Super heterodyne receiver, Sensitivity, Selectivity, Image frequency and its rejection, image frequency and IF amplifiers, AGC- diode detector, AFC, FM receivers – Amplitude limiting, Stereo-ponic FM multiplex system. Propagation of waves in free space –Ground wave propagation, surface wave propagation, ionospheric propagation – critical frequency, MUF, Skip distance.

Module IV

Sampling - reconstruction - aliasing - PAM, PWM, PPM – TDM – FDM-CDMA - noise in pulse modulation, Pulse code modulation. Quantization noise - Companding law - The PCM system. Digital modulation technique ASK, FSK, PSK, DPSK

Text book:

1. Communication systems- A. Bruce Carlson, Paul B. Crilly
2. Electronic Communication Systems - Kennedy and Davis
3. Communication Systems : Simon Haykins, John Wiley & Sons, Inc., 4th Edition, 2001
4. Principles of Communication : Taub and Schilling
5. Electromagnetic wave propagation, KD Prasad

References

1. Digital Communications Fundamentals and Applications: Bernard Sklar, Person Education, 2nd edition
2. Modern Digital and Analog communication system: B.P.Lathi, Oxford University Press, 3rd edition

Structure of Question Paper

The External question paper is of 2.5 hours duration with 80 marks. Question paper shall consist of three sections. Section A contains 15 short answer type questions of 2 marks each spanning the entire syllabus and the candidate can score a maximum of 25 marks. Section B contains 8 paragraph / problem type questions of 5 marks each; two questions from each module (2 quest. x 4 module = 8 quest.), and the candidate can score a maximum of 35 marks. Section C contains 4 essay type questions of 10 marks each; one from each module, of which candidate has to answer 2.

Core Course 9

ELE6B14 - Principles of DSP

Contact Hours per Week: 7 (4T + 3L)

Number of Credits: 4

Number of Contact Hours: 60 Hrs.

Course Outcome

To equip the students with basic knowledge in DSP

To learn the basics signals and analysis, Fourier transforms, digital filter design etc

Course Outline

Module I

Signals – Various types and classifications – Uni-dimensional and multi-dimensional-Analog, Discrete and Digital Signals- Energy and power signals, Causal and non-causal signals- even and odd

signals-Representation methods-Functional, Graphical, Tabular and Sequential Important test signals. Mathematical operations on discrete time signals- signal as summation of impulses.

Laplace transformation-definition-properties- Fourier transform on discrete signals (DTFT) - definition-properties-Z transform-definition and its properties.

Module II

Definition-various classifications-Static & Dynamic, Time invariant & Time variant, Linear & Nonlinear, Causal & Non causal, Stable & Unstable, FIR & IIR, Recursive & Non recursive-Excitation, response and Impulse response of system-their relations- transfer functions and its properties-Convolution- Linear and circular-their properties-sectioned convolution-overlap add and overlap save method.

Module III

DFT-definition-properties- relation between Z transform and DFT-computation techniques-FFT-radix 2 FFT-DIT FFT and DIF FFT- butterfly diagram- computation techniques.

Module IV

Filters: Comparison between Analog and Digital filters – comparison between FIR and IIR filters - IIR Filter Design by Impulse Invariance and Bilinear Transformation. Realization of IIR systems - Direct form I, Direct form II, Cascade representation and Parallel representation. Realization of FIR systems - Direct form representation and Cascade representation.

Text Book

1. Digital Signal Processing by A. NagoorKani
2. Digital signal processing - Ramesh Babu.
3. Digital signal Processing by S Salivahan

References

1. Digital Signal Processing by Proakis & Manolokis

Structure of Question Paper

The External question paper is of 2.5 hours duration with 80 marks. Question paper shall consist of three sections. Section A contains 15 short answer type questions of 2 marks each spanning the entire syllabus and the candidate can score a maximum of 25 marks. Section B contains 8 paragraph / problem type questions of 5 marks each; two questions from each module (2 Que x 4 module = 8 quest.), and the candidate can score a maximum of 35 marks. Section C contains 4 essay type questions of 10 marks each; one from each module, of which candidate has to answer 2.

Core Course 10

ELE6B15 - Microwave Theory and Techniques

Contact Hours per Week: 4 (4T)

Number of Credits: 4

Number of Contact Hours: 60 Hrs.

Course Outcome

To equip the students with basic understanding of Microwave theory and techniques

Course Outline

Module I

An introduction to Microwaves: Introduction, Frequency spectrum, Micro wave bands, Applications of microwaves in different fields, Plane waves and free space propagation, Guided waves-slow waves and fast waves- wave guides, rectangular wave guides, TE and TM waves, Transverse electromagnetic waves, group and phase velocities.

Module II

Basics of transmission lines and waveguides: Transmission lines and wave guides, Review of transmission lines, Telegraph equations, group and phase velocities, characteristic Impedance-open circuit, closed circuit, quarter wavelength and half wavelength lines, Standing wave ratio, VSWR, Reflection coefficient, Impedance matching, strip/microstrip transmission lines, microwave guides, propagation through wave guides, cut off frequency and dispersion-wave and group velocity, Ridged waveguides-applications, cavity resonator design equations, Waveguide Tees, Magic Tees, Rat Race, Directional couplers, Isolators and circulators.

Module III

Microwave Linear beam tubes and Cross field devices: Microwave tubes, Introduction, limitations of conventional tubes, Transit time effects, Multi cavity Klystron, reentrant cavities, Velocity modulation and beam bunching, bunching diagrams, reflex klystron, magnetron, working of magnetron, travelling wave tubes-slow wave structures amplification mechanism, Forward and backward wave Cross field amplifiers-principle of operation-microwave characteristics.

Module IV

Transferred Electron devices and transit time devices: Microwave Semiconductor devices, Tunnel diodes- negative resistance-band theory for forward and reverse biasing, Schottky diodes, Point contact diodes, Varactor diodes, IMPATT diode-structure-negative resistance-efficiency and output power, TRAPATT diode-principle of operation and performance, Gunn effect and Gunn diode-modes of operation-oscillation modes- Applications.

Text books

1. Microwave devices and circuits, Samuel Y. Lio (Prentice Hall)

2. Fundamentals of microwave engineering –Collins (Wiley India)
3. Electronic communication systems – Kennedy and Davis (Tata Mc Graw Hill)

Structure of Question Paper

The External question paper is of 2.5 hours duration with 80 marks. Question paper shall consist of three sections. Section A contains 15 short answer type questions of 2 marks each spanning the entire syllabus and the candidate can score a maximum of 25 marks. Section B contains 8 paragraph / problem type questions of 5 marks each; two questions from each module (2 quest. x 4 module = 8 quest.), and the candidate can score a maximum of 35 marks. Section C contains 4 essay type questions of 10 marks each; one from each module, of which candidate has to answer 2.

Core Lab 7

ELE6B18 - Communication System Lab

Contact Hours per Week: 3L

Number of Credits: 2

Number of Contact Hours: 45 Hrs.

List of experiments:

1. Amplitude modulation and demodulation
2. Frequency Response of IF Amplifier
3. Mixer
4. Frequency Modulation and Demodulation
5. Pre-emphasis and De-emphasis
6. Pulse Amplitude Modulation & Demodulation
7. Pulse width Modulation and Demodulation
8. Pulse Position modulation and Demodulation
9. Voltage Controlled Oscillator using 555.
10. Study of TDM using IC
11. Amplitude Shift Keying
12. Frequency Shift Keying

Core Lab 8

ELE6B19 - Principles of DSP Lab

Contact Hours per Week: 3 (3L)

Number of Credits: 2

Number of Contact Hours: 45 Hrs.

List of experiments:

1. Familiarization with DSP simulation software
2. Generation Continuous time signals
3. Generation of AM and FM signals
4. Generation of Discrete time signals
5. Sampling and reconstruction
6. Mathematical Operations on discrete time signals
7. Discrete Time Systems - Checking for Linearity, Time invariance and stability
8. Linear convolution and Circular convolution
9. Impulse response of LTI system
10. Impulse response from transfer function of the system
11. Computation of n-point DFT and IDFT
12. FIR and IIR filter design – Low pass, High Pass, Band Pass and Band Stop

Core Lab 9

ELE6B20 – Industrial Visit Report (5th sem.) & Project Work

Project Work

Contact Hours per Week: 4 (4L)

Number of Credits: 1+2

Number of Contact Hours: 60 Hrs.

- This project work is the continuation of the project initiated in 5th semester.
- The performance of the students in the project work shall be assessed on a continuous basis by the project monitoring committee through progress seminars and demonstrations conducted during the semester.
- There shall be at least an Interim Evaluation (after 20 project hours of 6th semester) and a final evaluation of the project in the 6th semester.

- Each project group has to submit an interim report in the prescribed format for the interim evaluation.
- Each project group should complete the project work within 45 project hours of the 6th semester.
- Each student is expected to prepare a report in the prescribed format, based on the project work. Project report certified by the internal guide and head of the department is the eligibility for appearing university examination.
- Members of the group will present the relevance, design, implementation, and results of the project before the external and internal examiner.
- A committee of External examiner, Internal Examiner and Guide may conduct a viva – voce to examine the knowledge acquired by the student during their project work (not programme viva voce).

Distribution of Marks

Internal (20%)		External (80%)	
<i>Components</i>	% of Marks	<i>Components</i>	% of Marks
Punctuality and Log Book	20	Relevance of the Topic, Statement of Objectives, Methodology (Reference/ Bibliography)	20
Skill of doing project work	20	Presentation, Quality of Analysis/Use of Statistical tools, Findings and recommendations	30
Scheme/Organization of Report	30		
Viva-Voce	30	Viva-Voce	50

Open Courses - V Semester

Open Course1

ELE5D01 – Computer Hardware

Contact Hours per Week: 3 (3T)

Number of Credits: 3

Number of Contact Hours: 45 Hrs.

Course Outcome

To equip the students with a knowledge in computer hardware.

Course Outline

Module I

Evolution of Computers and Computer Generations, Computer Classification Processing speed of a computer, Technology Trends, Measuring Computer Performance, Architecture, Functional Units and Components in Computer Organization, Computers – Block diagram, Memory addressing capability of a CPU, Word length of a computer, Basic components of a Digital Computer - Control unit, ALU, IO Subsystem of a Computer, Bus Structures, Uses of Program Development Tool, Editor, Compiler, Assembler, Interpreter.

Module II

Number systems – Decimal Number system, Binary number system and Hexa-decimal number system, 1's & 2's complement, Representation of Positive and Negative Numbers, Binary Fixed- Point Representation, Arithmetic operation on Binary numbers, Codes, ASCII Logic Gates, AND, OR, NOT GATES and their Truth tables.

Module III

Input Devices - Keyboard, Mouse, Output Devices - CRT Monitor, LCD Displays, Touch Screen Displays Print Devices, Multiprocessor and Multi core Architecture

Text Book

□ Computer Fundamentals – B. Ram – New Age International Publishers

Reference BOOKS

1. Rashid Sheikh, “Computer Organization & Architecture”
2. Computer Organization – Hamacher, Vranesic and Zaky, McGraw Hill.

3. Digital Logic and Computer Design – Morris Mano, PHI
4. Computer Organization and Architecture -William Stallings, Pearson Education Asia.
5. Computer Organization and Design – Pal Chaudhuri, PH

Open Course2

ELE5D02 – Digital Fundamentals

Contact Hours per Week: 3 (3T)

Number of Credits: 3

Number of Contact Hours: 45 Hrs.

Course Outcome

To equip the students with detailed knowledge in digital electronics. To learn different number systems, logic gates, counters, flip flops etc

Course Outline

Module I

Number System and Codes: Decimal, Binary, Hexadecimal, Octal, BCD, conversion of one code to another, Complements (one's and two's), Addition and Subtraction, Multiplication Logic Gates and Boolean algebra: Truth Tables, OR, AND, NOT, XOR, NOR, NAND, Universal (NOR and NAND) Gates, Boolean Theorems, DeMorgan's Theorems.

Module II

Combinational Logic Analysis and Design: Standard representation of logic functions (SOP and POS), Karnaugh map minimization. Adder (half and full) and subtractor.

Module III

Sequential logic design: Latch, Flip flop (FF), SR FF, JK –master slave FF, T and D type FFs, Clocked FFs, Registers, Counters (synchronous and asynchronous)

References

1. R.L. Tokheim, Digital Principles, Schaum's Outline Series, Tata McGraw-Hill (1994)
2. Donald P. Leach, Albert Paul Malvino, Digital Principles and Applications, Tata McGraw Hill (1995)
3. M. Morris Mano, Michael D. Ciletti, Digital Design, Pearson Education Asia, (2007)
4. Thomas L. Floyd, Digital Fundamentals, Pearson Education Asia (1994)
5. S.P. Bali, Solved Problems in Digital Electronics, Sigma Series, Tata McGraw-Hill, (2005)
6. W. H. Gothmann, Digital Electronics: An Introduction To Theory And Pra

Open Course3

ELE5D03 – Electronic Fundamentals

Contact Hours per Week: 3 (3T)

Number of Credits: 3

Number of Contact Hours: 45 Hrs.

Course Outcome

To equip the students with basic components in electronics, identifying and testing them, various measuring and testing instruments, assembling of electronic circuits and basic techniques of troubleshooting.

- To learn the basics of electronic components
- To learn the basics of testing and measuring instruments
- To learn the circuit assembling
- To study circuit troubleshooting

Course Outline

Module I

Voltage and Current: Concepts of emf, potential difference and current, resistance, capacitance and inductance, S.I. units of work, power and Energy, concept of Kilo Watt Hour, Module 2: Batteries and cells, their types, primary cells and secondary cells, Lead Acid, Ni- Cd, Ni-MH and Li-ion batteries, current capacity and cell ratings, charging and discharging of batteries, importance of initial charging, maintenance procedure, series and parallel battery connections.

Module II

D.C. Circuits : Resistance in Series and Parallel circuits, Shorts and Opens in series and Parallel circuits, Ohm's law, Kirchhoff's Voltage and current laws, Determination of direction of current and voltage sign, applications, Simplifications of networks using series and parallel combinations.

Module III

AC fundamentals : Generation of alternating voltages and currents, Transformer, Equations of AC voltage and current, Simple wave forms, concept of time period, frequency, amplitude and phase, Peak value and RMS value of amplitude, AC through resistance inductance and capacitance.

Reference

A text book of Electrical Technology, B L Theraja and A K Theraja

Elective Courses - VI Semester

Elective Course1

ELE6B16a – Optical Communication

Contact Hours per Week: 3 (3T)

Number of Credits: 3

Number of Contact Hours: 45 Hrs.

Course Outline

Module I

Advantages of optical Communication-Recollection of basic principles of optics transmitting light on a fiber, light propagation in fibers and characteristics, Critical angle - Total internal reflection. Classification of Fibers: Single mode and multimode Fibers, Step index and Graded index Fibers – Refractive Index profile - Effect of index profile on propagation - Acceptance angle - acceptance cone – Numerical aperture - Mode field diameter, Cut off wavelength

Module II

Signal degradation in optical fibers: Attenuation in single mode and multimode fibers – Absorption loss, scattering loss and bending loss - Dispersion – Material dispersion, Waveguide dispersion, modal dispersion, Polarization mode dispersion - Band Width limitation.

Module III

Optic fiber couplers: types of couplers – Fiber to fiber joints: Splicing techniques- Fusion splice, V groove splice, Elastic tube splice - Optical fiber connectors -Structure of a connector Optical Communication System, point to point transmission systems, modulation, transmission system limits and characteristics, optical systems engineering,

Module IV

Optical sources and detectors: light production, LEDs, characteristics, lasers, DFB lasers, tunable DBR lasers, photoconductors, photodiodes, and phototransistors, Optical receiver - Optical amplifiers- SOAs – EDFAs

Text Books

1. G. Keiser, Optical Fiber Communications, 3/e, MGH 2000
2. John M senior, Optic Fiber Communication, PHI.

References:

1. J.R. Dutton, Understanding Optical Communications, Prentice Hall, 1999.

2. D K Myabaev & L L Scheiner, Fiber Optics Communications Technology, Pearson Education, 2001.
3. G.P. Agrawal, Fiber Optic Communication, John Wiley & Sons.
4. J H Franz & V.K Jain, Optical Communication, Narosa Publishing House, 2001.
5. Subir Kumar Sarkar, Optical Fibre and Fibre Optic Communication, S Chand & Co. Ltd.
6. Djafer K Mynbaev, Fibre Optic Communication technology, Pearson Education.

Structure of Question Paper

The External question paper is of 2 hours duration with 60 marks. Question paper shall consist of three sections. Section A contains 12 short answer type questions of 2 marks each, and the candidate can score a maximum of 20 marks. Section B contains 7 paragraph / problem type questions of 5 marks each and the candidate can score a maximum of 30 marks. Section C contains 2 essay type questions of 10 marks each of which candidates has to answer 1 question and can score a maximum of 10 mark. Questions must be distributed uniformly covering all modules.

Elective Course2

ELE6B16b – Industrial Electronics

Contact Hours per Week: 3 (3T)

Number of Credits: 3

Number of Contact Hours: 45 Hrs.

Course Outline

Module I

Power semiconductor devices: Characteristics of SCR, gate trigger and commutation circuits, series and parallel connection of SCRs, Diac, Triac, UJT, Power MOSFETS and IGBT.

Module II

Controlled Rectifier Half wave and full wave with resistive and inductive loads, Free– wheeling diode, and three phase rectifier. Bridge rectifiers–half controlled and fully controlled.

Module III

DC choppers: Principle of chopper operation and control strategies, Step-up and stepdown choppers, Types of chopper circuits, Voltage-commutated chopper, Current-commutated chopper, Load-commutated chopper. Inverters: single-phase voltage source inverters, Modified McMurray half-bridge and full-bridge inverter, Pulse-width modulated inverters, Series and Parallel inverter.

Module IV

Induction Heating, effect of frequencies and power requirements, Dielectric heating and applications. Applications of industrial electronics Switched mode power supply (SMPS), Uninterruptible power supplies, Solid state relays.

Text Books

1. Muhammad H. Rashid, Power Electronics: Circuits, Devices and Applications, Pearson / PHI.
2. Dr. P. S. Bimbhra, Power Electronics, Khanna Publishers.

References

1. P. C. Sen, Power Electronics, Tata McGraw Hill.
2. S.K. Dutta, Power Electronics and Control, PHI.
3. SN Biswas, Industrial Electronics, Dhanpat Rai & Sons, 2005.
4. C. W. Lander, Power Electronics, McGraw Hill.

Structure of Question Paper

The External question paper is of 2 hours duration with 60 marks. Question paper shall consist of three sections. Section A contains 12 short answer type questions of 2 marks each, and the candidate can score a maximum of 20 marks. Section B contains 7 paragraph / problem type questions of 5 marks each and the candidate can score a maximum of 30 marks. Section C contains 2 essay type questions of 10 marks each of which candidates has to answer 1 question and can score a maximum of 10 mark. Questions must be distributed uniformly covering all modules.

**** Hands on Exercise**

Suggested Experiments:

1. Study of IV characteristics of SCR
2. SCR as half wave rectifier and full wave rectifier with R and RL loads
3. AC voltage controller using TRIAC with UJT triggering
4. Study of IV characteristics of DIAC
5. Study of IV characteristics of TRIAC

** The “hands on Exercise” may be considered for Internal evaluation

Elective Course 3

ELE6B16c – Control Systems

Contact Hours per Week: 3 (3T)

Number of Credits: 3

Number of Contact Hours: 45 Hrs.

Course Outcome

To equip the students to have basic understanding in control systems and its design.
To learn the basics of control systems modelling, Analysis of control system, design etc.

Course Outline

Module I

Basics of control system, classification of control system, open loop, closed loop, examples Servomechanism, feedback and feed forward system, Basics of Laplace Transform, Use of Laplace transform in control system.

Module II

Transfer function, Impulse response, poles, zeroes, pole-zero plot, order and type number, Mathematical modeling of control system, Mechanical, rotational and electrical systems, servomotors, speed control system.

Module III

Block diagram representation; block diagram reduction, signal flow graph, Mason's gain formula, Time response analysis, standard test signals, steady state error, Analysis of first and second order system. Time domain specifications.

Module IV

Frequency domain analysis, Frequency domain specifications, frequency response plots, Bode plot, polar plot, stability analysis, Routh Hurwitz criterion, Nyquist stability, concept of Root locus-Controllers –PI,PD,PID ,Compensators-Lag, lead, Lag-lead

Text Books

1. Control Systems – Nagoor Kani
2. Control System Engineering-U.A Bakshi , V.U Bakshi

References

1. J Nagrath & M. Gopal, Control System Engineering, New Age International, 2000
2. Benjamin C. Kuo , “Automatic control system”, Prentice Hall of India, 2000

Structure of Question Paper

The External question paper is of 2 hours duration with 60 marks. Question paper shall consist of three sections. Section A contains 12 short answer type questions of 2 marks each, and the candidate can score a maximum of 20 marks. Section B contains 7 paragraph / problem type questions of 5 marks each and the candidate can score a maximum of 30 marks. Section C contains 2 essay type questions of 10 marks each of which candidates has to answer 1 question and can score a maximum of 10 mark. Questions must be distributed uniformly covering all modules.

Elective Course 4

ELE6B16d – Verilog & FPGA Based System Design

Contact Hours per Week: 3 (3T)

Number of Credits: 3

Number of Contact Hours: 45 Hrs.

Course Outline

Module I

Digital logic design flow. Review of combinational circuits. Combinational building blocks: multiplexers, demultiplexers, decoders, encoders and adder circuits. Review of sequential circuit elements: flip-flop, latch and register.

Module II

Finite state machines: Mealy and Moore. Other sequential circuits: shift registers and counters. FSM (Finite State Machine with Datapath): design and analysis. Microprogrammed control. Memory basics and timing. Programmable Logic devices.

Module III

Evolution of Programmable logic devices. PAL, PLA and GAL. CPLD and FPGA architectures. Placement and routing. Logic cell structure, Programmable interconnects, Logic blocks and I/O Ports. Clock distribution in FPGA. Timing issues in FPGA design. Boundary scan.

Module IV

Verilog HDL: Introduction to HDL. Verilog primitive operators and structural Verilog Behavioral Verilog. Design verification. Modeling of combinational and sequential circuits (including FSM and FSM) with Verilog Design examples in Verilog.

References

1. Lizy Kurien and Charles Roth. Principles of Digital Systems Design and VHDL. Cengage Publishing. ISBN-13: 978-8131505748
2. Palnitkar, Samir, Verilog HDL. Pearson Education; Second edition (2003).
3. Ming-Bo Lin. Digital System Designs and Practices: Using Verilog HDL and FPGAs. Wiley India

Pvt Ltd. ISBN-13: 978-8126536948

4. Zainalabedin Navabi. Verilog Digital System Design. TMH; 2nd edition
5. Wayne Wolf. FPGA Based System Design. Pearson Education.
6. S. K. Mitra, Digital Signal processing, McGraw Hill, 1998
7. VLSI design, Debaprasad Das, 2nd Edition, 2015, Oxford University Press.
8. D.J. Laja and S. Sapatnekar, Designing Digital Computer Systems with Verilog, Cambridge University Press, 2015

Structure of Question Paper

The External question paper is of 2 hours duration with 60 marks. Question paper shall consist of three sections. Section A contains 12 short answer type questions of 2 marks each, and the candidate can score a maximum of 20 marks. Section B contains 7 paragraph / problem type questions of 5 marks each and the candidate can score a maximum of 30 marks. Section C contains 2 essay type questions of 10 marks each of which candidates has to answer 1 question and can score a maximum of 10 mark. Questions must be distributed uniformly covering all modules.

****Hands On Exercise**

Suggested Experiments

At Least 08 Experiments from the Following:

1. Write code to realize basic and derived logic gates.
2. Half adder, Full Adder using basic and derived gates.
3. Half subtractor and Full Subtractor using basic and derived gates.
4. Design and simulation of a 4 bit Adder.
5. Multiplexer (4x1) and Demultiplexer using logic gates.
6. Decoder and Encoder using logic gates.
7. Clocked D, JK and T Flip flops (with Reset inputs)
8. 3-bit Ripple counter
9. To design and study switching circuits (LED blink shift)
10. To design traffic light controller.
11. To interface a keyboard
12. To interface a LCD using FPGA
13. To interface multiplexed seven segment display.
14. To interface a stepper motor and DC motor.
15. To interface ADC 0804.

** "Hands on Exercise" may be considered for Internal Evaluation

Reference Books:

1. W. Wolf, FPGA- based System Design, Pearson, 2004
2. U. Meyer Baese, Digital Signal Processing with FPGAs, Springer, 2004 • S. Palnitkar,
3. Verilog HDL– A Guide to Digital Design & Synthesis, Pearson, 2003
4. Verilog HDL primer- J. Bhasker. BSP, 2003 II edition

Electronics Complementary Syllabus

Curriculum for Complementary ELECTRONICS

Semester	Course Code	Course Title	Marks			Contact Hours			Credits
			Internal	External	Total	Theory	Lab	Total	
I	ELE1C01	Electronic Devices	15	60	75	2	2	4	2
II	ELE2C02	Electronic Circuits	15	60	75	2	2	4	2
II	ELE2C03	Electronic Devices and Circuits Lab	15	60	75	-	-	-	2
III	ELE3C04	Digital Electronics	15	60	75	3	2	5	2
IV	ELE4C05	Communication Electronics Lab	15	60	75	3	2	5	2
IV	ELE4C06	Digital and Communication Electronics Lab	15	60	75	-	-	-	2

Semester I

Complementary Course 1

ELE1C01 - Electronic Devices

Contact Hours per Week: 4 (2T + 2L)

Number of Credits: 2

Number of Contact Hours: 45 Hrs.

Course Outcome

To equip the students with basic components in electronics, identifying and testing them, various measuring and testing instruments, assembling of electronic circuits and basic techniques of troubleshooting.

- To learn the basics of electronic components
- To learn the basics of testing and measuring instruments
- To learn the circuit assembling
- To study circuit troubleshooting

Course Outline

Module I

Introduction to electronics: Components - passive and active components- Resistors, capacitors, inductors types-identification-colour coding. Circuit control and protective devices- switches, fuses and relays, Printed Circuit Board

Module II

Fundamentals of electronics – Band theory, conductors, insulators, semiconductors. Intrinsic and extrinsic semiconductors, PN junction, diode, biasing and characteristics, breakdown, diode resistance and capacitance, switching diode, zener diode

Module III

Structure and operation of LDR, Photo voltaic cell, Photo diode, LED and LCD.

Module IV

Bipolar junction transistor, operation, transistor configurations, characteristics and their comparison, current transfer ratio, transistor as a switch.

Module V

FET, structure, characteristics, parameter terminal current, transconductance model, comparison between BJT and FET, applications, MOSFET, types and characteristics, UJT.

Text book

Textbook of Applied electronics – R.S Sedha.

References

1. Principles of electronics- V.K Metha.
2. Basic electronics and linear circuits – N.N Bhargava, Kurukshetra and Gupta.
- 3 Electronics Engineering - B.L.Theraja

Electronic Devices Lab

List of experiments:

1. Familiarization of electronic components.
2. Familiarization of equipment like CRO, Signal generators.
3. Characteristics of PN junction diode.
4. Characteristics of zener diode.
5. Characteristics of LED.
6. FET Characteristics.
7. Characteristics of transistor in CE and CB configurations.
8. RC differentiator and integrator circuits.

Semester II

Complementary Course 2

ELE2C02 - Electronic Circuits

Contact Hours per Week: 4 (2T + 2L)

Number of Credits: 2

Number of Contact Hours: 45 Hrs.

Course Outline

Module I

Rectifier circuits, half wave rectifier, full wave rectifier, bridge rectifier, Ripple factor, General filter consideration, different type of filters, comparison, voltage regulators – zener diode regulator, Three terminal regulators (78XX and 79XX) – Principle and working of switch mode power supply (SMPS).

Module II

Biasing of BJT- Q-point, stability factor and biasing circuits, BJT amplifiers, RC-coupled amplifiers, frequency response, voltage gain, current gain, input resistance and output resistance, comparison of BJT amplifiers concept of gain – applications.

Module III

Feedback amplifier, positive and negative feed back, Types of feed back, applications, power amplifier – class A , class B and class C amplifiers.

Module IV

Oscillators - sinusoidal oscillators, Barkhausen criteria, RC-oscillators, LC oscillators, crystal oscillators, multivibrators, typical oscillators, applications, 555 timer – astable and monostable mode

Text book

Textbook of Applied electronics – R.S Sedha.

References

1. Principles of electronics- V.K Metha.
2. Basic electronics and linear circuits – N.N Bhargava, Kurukshetra and Gupta.
3. Electronics Engineering - B.L.Theraja.

Electronic Circuits Lab

List of experiments:

1. Rectifier circuits (Half wave, Full wave and bridge rectifiers) and filters.
2. Voltage regulator using zener diode.
3. CE amplifier (determination of voltage gain).
4. Astable multivibrator using BJT.
5. RC phase shift oscillator.
6. Astable multivibrator using 555.
7. Monostable multivibrator using 555.

Practical Lab1

ELE2C03: Electronic Devices and Circuits Lab

Number of Credits: 2

1. Familiarization of electronic components.
2. Familiarization of equipment like CRO, Signal generators.
3. Characteristics of PN junction diode.
4. Characteristics of zener diode.
5. Characteristics of LED.
6. FET Characteristics.
7. Characteristics of transistor in CE and CB configurations.
8. RC differentiator and integrator circuits.
9. Rectifier circuits (Half wave, Full wave and bridge rectifiers) and filters.
10. Voltage regulator using zener diode.
11. CE amplifier (determination of voltage gain).
12. Astable multivibrator using BJT.
13. RC phase shift oscillator.
14. Astable multivibrator using 555.
15. Monostable multivibrator using 555.

Semester III

Complementary Course 3

ELE3C04 - Digital Electronics

Contact Hours per Week: 5 (3T + 2L)

Number of Credits: 2

Number of Contact Hours: 45 Hrs.

Course Outline

Module I

Number System and Codes: Decimal, Binary, Hexadecimal, Octal, BCD, conversion of one code to another, Complements (one's and two's), Signed and Unsigned numbers, Addition and Subtraction, Multiplication .Logic Gates and Boolean Algebra: Truth Tables, OR, AND, NOT, XOR, XNOR, Universal (NOR and NAND) Gates, Boolean Theorems, DeMorgan's Theorems, Principle of duality.

Module II

Combinational Logic Analysis and Design: Standard representation of logic functions (SOP and POS), Karnaugh map minimization. Multiplexers and Demultiplexers, Implementing logic functions with multiplexer, Adder (half and full) and subtractor, Encoder and Decoder.

Module III

Sequential logic design: Latch, Flip flop (FF), S-R FF, J-K FF, T and D type FFs, Clocked FFs, Registers, Counters (synchronous and asynchronous, ring, modulo-N), Shift registers – Serial and parallel

Module IV

Memories: General Memory Operation, ROM, RAM (Static and Dynamic), PROM, EPROM, EEPROM, EAPROM

References

1. R.L. Tokheim, Digital Principles, Schaum's Outline Series, Tata McGraw-Hill (1994)
2. Donald P. Leach, Albert Paul Malvino, Digital Principles and Applications, Tata McGraw Hill (1995)
3. M. Morris Mano, Michael D. Ciletti, Digital Design, Pearson Education Asia, (2007)
4. Thomas L. Floyd, Digital Fundamentals, Pearson Education Asia (1994)
5. S.P. Bali, Solved Problems in Digital Electronics, Sigma Series, Tata McGraw-Hill, (2005)

6. W. H. Gothmann, Digital Electronics: An Introduction to Theory And Practice, Prentice Hall of India (2000)
7. R.P. Jain, Modern Digital Electronics, Tata McGraw-Hill (2003)

Digital Electronics Lab

List of experiments:

1. Familiarization of logic gates using ICs (NOT, OR, AND, XOR, NAND, NOR).
2. Realization of basic gates using NAND & NOR
3. Design a Half and Full adder
4. Design a Half and Full Subtractor.
5. Design a 4x1 Multiplexer using logic gates
6. Multiplexers and Demultiplexer using ICs
7. Study of RS and D flip flops
8. Design a 3 bit Counter using JK Flip-Flop IC

Semester IV

Complementary Course 4 ELE4C05 - Communication Electronics

Contact Hours per Week: 5 (3T + 2L)

Number of Credits: 2

Number of Contact Hours: 45 Hrs.

Course Outline

Module I

Electronic communication: Block diagram of an electronic communication system, electromagnetic spectrum-band designations and applications, need for modulation, Amplitude Modulation: Amplitude Modulation, modulation index and frequency spectrum. Generation of AM, Amplitude Demodulation (diode detector).

Module II

Angle modulation: Frequency and Phase modulation, modulation index and frequency spectrum, equivalence between FM and PM, Generation and demodulation of FM – Types – De-emphasis and Pre-emphasis, FM detector (PLL). Comparison between AM, FM and PM.

Module III

Pulse Analog Modulation: Channel capacity, Sampling theorem, PAM, PDM, PPM, Multiplexing, TDM and FDM. Pulse Code Modulation: Need for digital transmission, Quantizing, Quantization Noise, Companding, Coding, Decoding, and Regeneration.

Module IV

Digital Carrier Modulation Techniques: Block diagram of digital transmission and reception, Information capacity, Bit Rate and Baud Rate. Amplitude Shift Keying (ASK), Frequency Shift Keying (FSK), Phase Shift Keying (PSK), Binary Phase Shift Keying (BPSK) and Quadrature Phase Shift Keying (QPSK).

Text Book

1. Electronic communication systems- Kennedy, 3rd edition, McGraw international publications
2. Principles of Electronic communication systems – Frenzel, 3rd edition, McGraw Hill
3. Modern Digital and Analog Communication Systems, B.P. Lathi, 4th Edition, 2011, Oxford University Press.

Reference Books

1. Electronic Communications -D. Roddy and J. Coolen, Pearson Education India.
2. Advanced Electronics Communication Systems- Tomasi, 6th edition, Prentice Hall.
3. Communication Systems, S. Haykin, Wiley India (2006)
4. Advanced electronic communications systems – Tomasi, 6th edition, PHI.

Communication Lab

List of experiments:

1. To study Amplitude Modulator using Transistor
2. To study envelope detector for demodulation of AM signal
3. To study FM - Generator and Detector circuit
4. To study Time Division Multiplexing (TDM)
5. To study Pulse Amplitude Modulation (PAM)
6. To study Pulse Width Modulation (PWM)
7. To study Pulse Position Modulation (PPM)

Practical Lab 2

ELE4C06: Digital and Communication Electronics Lab

Number of Credits: 2

1. Familiarization of logic gates using ICs (NOT, OR, AND, XOR, NAND, NOR).
2. Realization of basic gates using NAND & NOR
3. Design a Half and Full adder
4. Design a Half and Full Subtractor.
5. Design a 4x1 Multiplexer using logic gates
6. Multiplexers and Demultiplexer using ICs
7. Study of RS and D flip flops
8. Design a 3 bit Counter using JK Flip-Flop IC
9. To study Amplitude Modulator using Transistor
10. To study envelope detector for demodulation of AM signal
11. To study FM - Generator and Detector circuit
12. To study Time Division Multiplexing (TDM)
13. To study Pulse Amplitude Modulation (PAM)
14. To study Pulse Width Modulation (PWM)
15. To study Pulse Position Modulation (PPM)

MODEL QUESTION PAPERS

**FIRST SEMESTER BSc ELECTRONIOCS DEGREE EXAMINATION
ELE1B01: BASIC ELECTRONICS AND NETWORK THEOREMS**

Time: 2 Hrs

MAX. MARKS: 60

Section A

Answer the following Questions (1-12), each carries 2 marks

1. State Mass Action Law?
2. Differentiate between open and short circuit?
3. Write colour code of following resistors: 1Ω and $4.7K\Omega$
4. Write down diode current equation?
5. State Kirchoff's laws?
6. How a voltage source is converted in to current source and vice versa?
7. Give examples for donor and acceptor atoms used in semiconductors?
8. Differentiate between drift current and diffusion current?
9. State Ohm's Law?
10. What is an UJT? Write any two applications.
11. Differentiate between ideal and real diode?
12. Draw the symbols of n channel Depletion MOSFET and NPN transistor?

Ceiling: 20 Marks

Part B: Short Essay Questions.

Answer all questions. Each carries 5 marks

13. State and explain Reciprocity Theorem? Check whether the given network is reciprocal or not?

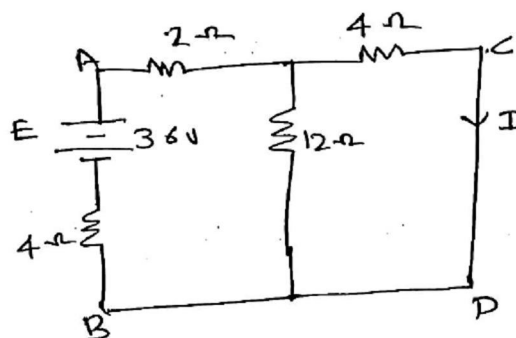

14. Write a short note on conductor, insulator and semiconductor with their energy band diagram?
15. Write down the expression (with the proof) for resistances, capacitors and inductors when each of them is connected in series and parallel?
16. State and prove Maximum Power Transfer Theorem?
17. Write a short note on passive and active electronic components?
18. Write a short note on working of LED and Zener diode?
19. Differentiate between BJT and FET?

Ceiling 30 marks

Part C: Essay Questions.

Answer any 1 question. Each carries 10 marks.

20. Explain working of a semiconductor p-n junction diode? Discuss about its characteristics and applications? State and explain Thevenin's theorem and Norton's theorem? Find current through the R_L using Thevenin's theorem of the given network?

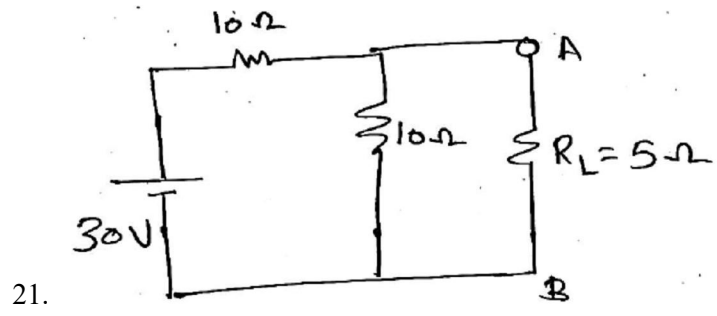

22. (a). Discuss about two port network and Z, Y and h parameters? State and explain Super position Theorem?
 (b). Find the current through the resistor R by using Super position Theorem?

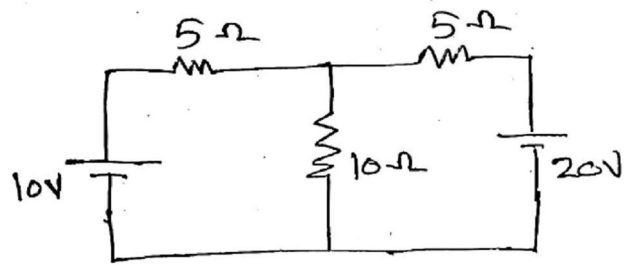

**SECOND SEMESTER BSc ELECTRONICCS DEGREE EXAMINATION
ELE2B02: ELECTRONIC CIRCUITS**

Time: 2 Hrs

MAX. MARKS: 60

Section A

Answer the following Questions (1-12), each carries 2 marks

1. Define stability factor?
2. Define line regulation and load regulation?
3. Write down the conditions for proper biasing of a transistor?
4. Write any two differences between voltage amplifier and power amplifier?
5. Draw the circuit of RC phase shift oscillator?
6. What are the factors which affect the frequency stability of an oscillator?
7. Differentiate between voltage series and voltage shunt feedback connection?
8. Why bias stabilization is not needed in common base circuit?
9. What is a clamping circuit?
10. Differentiate between positive feedback and negative feedback?
11. What are hybrid parameters?
12. Give the Barkhausen criteria required for sinusoidal oscillations to be sustained?

Ceiling: 20Marks

- **Section B**

Answer the following Questions (13-19), each carries 5 marks

13. Explain self bias circuit?
14. Compare the characteristics of three rectifier circuits?
15. What is a tuned voltage amplifier? Explain it briefly.
16. Explain Zener diode Series regulator using necessary circuit?
17. Compare Class A, Class B and Class C amplifiers?
18. Explain briefly Hartely oscillator circuit?
19. Derive the ripple factor of fullwave rectifier?

Ceiling: 30Marks

Section C

Answer any one question (20-21), carries 10 marks

20. With the help of neat circuit diagram and waveform explain astable multivibrator?
21. Explain any one type of fullwave rectifier with and without filter?

1x10=10 Marks

**THIRD SEMESTER BSc ELECTRONICS DEGREE EXAMINATION
ELE3B05- DIGITAL ELECTRONICS**

Time: 2 Hrs.

Max. Marks: 60

Section A

Answer the following Questions (1-12), each carries 2 marks

1. Differentiate between SOP and POS.
2. Draw the circuit of OR gate using NAND gates.
3. What is the binary equivalent of decimal number 464?
4. Draw the truth table for full adder circuit.
5. Can we consider EXOR gate as a comparator? Why?
6. Explain the characteristics of ECL.
7. Why JK flip flop is different from SR flip flop?
8. What is the need of select lines in multiplexers?
9. What are the various states of a 4 bit ring counter?
10. Define decade counter.
11. Differentiate between asynchronous counters and synchronous counters.
12. Mention any two methods for digital to analog conversion.

Ceiling: 20Marks

- **Section B**

Answer the following Questions (13-19), each carries 5 marks

13. Prove $A + \hat{A}B = A + B$; Also construct truth table.
14. Design a full subtractor circuit.
15. Explain the working of shift registers.
16. Explain the working of successive approximation method.
17. Draw the circuit of a 4 bit synchronous counter and explain its working with the help of truth table.
18. Define multiplexers. Design a 4 to 1 multiplexer using gates.
19. Compare TTL and CMOS logic families.

Ceiling: 30Marks

Section C

Answer any one question (20-21), carries 10 marks

20. Explain the concept of Karnaugh map mapping, grouping and finding the minimized SOP and POS expressions in detail with suitable examples.
21. What are the various flip flops used in digital circuits. Explain each one in detail with the help of neat diagrams.

1x10=10 Marks

**FOURTH SEMESTER BSc ELECTRONIOCS DEGREE EXAMINATION
ELE4B06- ANALOG INTEGRATED CIRCUITS**

Time: 2 Hrs.

Max. Marks: 60

Section A

Answer the following Questions (1-12), each carries 2 marks

1. Explain voltage follower?
2. Draw the ideal voltage characteristics of op amp?
3. Write a short note on CMMR?
4. Draw the circuit diagram of instrumentation amplifier?
5. Distinguish between opamp closed loop open loop configurations?
6. Define slew rate?
7. Draw the pin diagram of 741 IC?
8. What is the condition for oscillation for a phase shift oscillator? Give the expression for frequency of oscillation?
9. Draw the wave form and explain Zero Crossing Detector?
10. List out the applications of mono stable multi vibrator and astable multi vibrator?
11. Draw the pin diagram of 3 terminal 7815 voltage regulator and design the circuit?
12. Explain Voltage Control Oscillator?

Ceiling: 20Marks

Section B

Answer the following Questions (13-19), each carries 5 marks

13. Draw and explain typical block diagram of operational amplifier?
14. Write a short note on summing and differential amplifier?
15. Explain and differentiate between triangular wave and saw tooth wave generators?
16. With neat diagram design a Wien bridge oscillator of 1 kHz? Explain the circuit with relevant wave forms?
17. Explain working and Characteristics of Typical comparator circuits using op amp?
18. Differentiate between Voltage to current and current to Voltage converter?
19. Draw the internal block diagram of 555 timer?

Ceiling: 30Marks

Section C

Answer any one question (20-21), carries 10 marks

20. Explain working of closed loop non inverting amplifier and obtain the expression for voltage gain, input resistance, output resistance, bandwidth and total output offset voltage.
21. Draw the block diagram, operating principles, parameters and applications of Phase Locked Loop?

1x10=10 Marks

**FIFTH SEMESTER BSc ELECTRONIOCS DEGREE EXAMINATION
ELE5B10-ELECTROMAGNETIC THEORY**

Time: 2.5 Hrs

Max. Marks: 80

Section A

Answer the following Questions (1-15), each carries 2 marks

1. Define vector. Find its magnitude and direction.
2. What is a Gradient? Express the gradient of a scalar function in Cartesian co-ordinate system.
3. What is a Del operator?
4. Find cylindrical coordinates using Cartesian coordinates x, y and z.
5. What are the applications of Gauss's law?
6. What is the relation between electric field intensity vector and potential at a point?
7. Deduce the Poisson's and Laplace equation.
8. Define electric flux and electric flux density.
9. State Ohm's law.
10. What is Lorentz force equation?
11. State whether the magnetic field is conservative or not.
12. Define magnetic vector potential.
13. Define intrinsic impedance in free space.
14. Explain Uniform plane wave.
15. What are the differences between TE and TM waves?

Ceiling: 25 Marks

Section B

Answer the following Questions (16-23), each carries 5 marks

16. Explain Spherical coordinate system. What is its significance in electromagnetic field theory?
17. Explain the physical interpretation of Divergence with example.
18. Explain Coulomb's law.
19. Deduce the expression of energy stored in a capacitor.
20. Derive the force between two current carrying wires.
21. Explain Biot-savarts law.
22. State Pointing theorem and deduce the expression of Poynting vector.
23. Define antenna parameters 1) Directivity 2) Gain 3) Antenna efficiency 4) Effective area 5) Effective height.

Ceiling: 35 Marks

Section C

Answer any two questions (24-27), each question carries 10 marks

24. Explain and deduce the expressions of:
 - 1) Divergence theorem
 - 2) Stokes theorem
25. Derive the boundary conditions among Dielectric-Dielectric and conductor-dielectric.
26. Explain Ampere's circuital law. Deduce the expression in integral form. Calculate the magnetic field intensity at a point due to infinite line current.
27. Derive and explain the Maxwell's equations in integral form.

2x10=20 Marks

Page 73 of 82

**FIFTH SEMESTER BSc ELECTRONIOCS DEGREE EXAMINATION
ELE 5B 11 – MICROCONTROLLER & INTERFACING**

Time: 2 Hrs

Max. Marks: 60

Section A

Answer the following Questions (1-12), each carries 2 marks

1. List the features of the 8051 Microcontroller.
2. Calculate the period of the machine cycle; the crystal oscillator frequency is 11.0592Hz.
3. What are the various special function registers of 8051-MC?
4. What are the advantages of Arduino?
5. List some 8051-MC applications in embedded systems.
6. List the major components of an MC.
7. What are the benefits of a subroutine?
8. Write a program to add two 16bit numbers.
9. Explain the variables of Arduino.
10. What are the functions of 'PC' and 'SP' in 8051-MC
11. Why should we use Arduino?
12. Show the status of the 'CY' and 'P' flags after the execution of the following instructions.
MOVA, #9AH
ADDA, 51H

Ceiling: 20Marks

Section B

Answer the following Questions (13-19), each carries 5 marks

13. Describe the function of following instructions,
a) DAA b) ACALL c) RLC A
14. Explain the pin specification of Arduino-Uno.
15. Briefly discuss PSW.
16. Explain 'PUSH' and 'POP' instructions.
17. Explain register banks of 8051-MC.
18. Briefly explain LH35 interfacing with Arduino.
19. Compare 'MP' and 'MC' based on instructions, registers, and its applications.

Ceiling: 30Marks

Section C

Answer any one question (20-21), carries 10 marks

20. Describe the various interrupts used in 8051-MC, mention their priorities, and address.
21. Explain with a neat sketch the pin diagram and function of each pin of 8051-MC.

1x10=10 Marks

**FIFTH SEMESTER BSc ELECTRONIOCS DEGREE EXAMINATION
ELE5B12 - NETWORK THEORY**

Time: 2.5 Hrs

Max. Marks: 80

Section A

Answer the following Questions (1-15), each carries 2 marks

1. Distinguish between short circuit and open circuit
2. Find the voltage across $10\ \Omega$ resistor, if two resistors $10\ \Omega$ and $30\ \Omega$ are connected in series across a $10\ \text{V}$ supply.
3. Comment about star delta transformation
4. Define Time constant in RC circuit
5. What are steady state and transient responses?
6. Distinguish between Active power and Reactive power
7. Define V_{rms} and V_{avg} of a sinusoidal signal
8. What is Power factor?
9. Explain the voltage current relation in an Inductor with phasor diagram
10. What is source transformation
11. What is Form factor?
12. Explain the term Complex impedance in an ac circuit.
13. State KCL and KVL
14. Explain the term current division.
15. What is mutual inductance?

Ceiling: 25 Marks

Section B

Answer the following Questions (16-23), each carries 5 marks

16. Derive the expression for transient current in RL circuit when it is excited by DC Voltage V at $t=0$
17. What is Selectivity of RLC circuit? Explain the relation between selectivity and Q factor
18. Briefly explain magnetic Coupling
19. For the given circuit, find the equation of current when the switch is opened from position 1 at $t=0$

20. Derive resonant frequency of series RLC circuit
21. A series circuit consisting of $R=20\ \Omega$, $L=0.2\ \text{H}$, $C=150\ \mu\text{f}$ fed by a supply of $230\ \text{V}$ $50\ \text{Hz}$. Find active power, reactive power and power factor
22. Derive an expression for RMS value of a half wave rectified alternating voltage signal
23. Explain various types of filters with gain or attenuation profile

Ceiling: 35 Marks

Section C

Answer any two questions (24-27), each question carries 10 marks

24. Using mesh analysis find all the mesh currents for the circuit given below

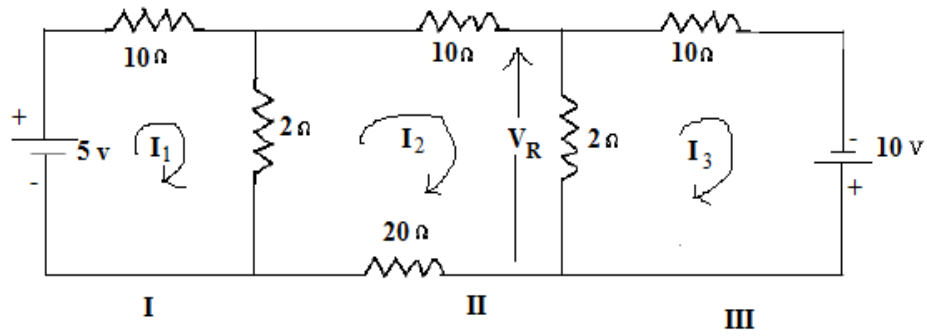

25. A series RLC circuit consist of $R=1K\Omega$, $L=100mH$, $C=100pF$. Find out Resonant frequency, Half power points and quality factor if a voltage of 100V is applied across the combination
26. Derive the expression for transient current through a series RLC circuit when it is excited by a DC voltage V.
27. A pure resistance of 50Ω is in series with a capacitance of $100\mu F$. The series combination is connected across 100V, 50Hz supply. Find **a)** the impedance **b)**current **c)** power factor **d)**phase angle **e)**Voltage across resistor

2x10=20 Marks

**FIFTH SEMESTER BSc ELECTRONICS DEGREE EXAMINATION
OPEN COURSE-ELECTRONICS
ELE5D02 Digital Fundamentals**

Time: 2 Hrs

Max. Marks: 60

Section A

Answer the following Questions (1-12), each carries 2 marks

1. Convert $(25)_{16}$ to Binary
2. Draw the truth table and symbol for AND gate.
3. Explain De Morgan's law.
4. Write a short note on BCD?
5. Draw the diagram of S-R flip flop.
6. Using Boolean techniques simplify the expression $AB+A(B+C)+B(B+C)$
7. Write the 2's complement of $(25)_{10}$?
8. Write the 2's complement of $(10)_{10}$?
9. Draw the truth table and symbol for XOR gate.
10. Explain De Morgan's law.
11. Write a short note on Hexadecimal number system?
12. Draw the diagram of D flip flop

Ceiling: 20Marks

Section B

Answer the following Questions (13-19), each carries 5 marks

13. Explain about Half adder and Full adder.
14. Write a short note T and D flip flops?
15. Write a short note on basic shift registers?
16. Write a short note S-R flip flop?
17. Write a short note on AND gates?
18. Design an OR gate using NAND gates?
19. Convert the given SOP to standard form and write its corresponding truth table
 $AB+ C'D'+ ABC'+ DB'$

Ceiling: 30Marks

Section C

Answer any one question (20-21), carries 10 marks

20. Explain in detail the concepts of logic gates with truth table and necessary diagram.
21. Discuss in detail about different counters in digital electronics

1x10=10 Marks

**SIXTH SEMESTER BSc ELECTRONIOCS DEGREE EXAMINATION
ELE6B13 –COMMUNICATION SYSTEMS**

Time: 2.5 Hrs

Max. Marks: 80

Section A

Answer the following Questions (1-15), each carries 2 marks

1. What do you meant by angle modulation?
2. What are the different forms of AM?
3. Define skip distance and MUF?
4. Define Image frequency and image frequency rejection ratio?
5. What do you meant by radio horizon?
6. What is modulation index and write the modulation index of AM and FM?
7. What do you meant by phase shift keying?
8. What is the necessity of modulation?
9. What are the advantages of SSB transmission?
10. State and explain Sampling theorem?
11. What is a pilot carrier?
12. What is quantization?
13. What do you meant by noise triangle?
14. Explain the power relation in AM?
15. What is aliasing?

Ceiling: 25 Marks

Section B

Answer the following Questions (16-23), each carries 5 marks

16. Differentiate FDM and TDM?
17. Explain varactor diode modulator?
18. Compare AM and FM?
19. With diagram, explain automatic frequency controller (AFC) in detail?
20. Explain the working of super heterodyne receiver?
21. Describe the operation of amplitude limiter?
22. Explain PWM?
23. Explain the working of discriminator circuit?

Ceiling: 35 Marks

Section C

Answer any two questions (24-27), each question carries 10 marks

24. Explain the different types of SSB generation techniques?
25. Explain with block diagram the transmission of stereophonic FM multiplex system?
26. With diagram, explain PCM system in detail?
27. Explain ground wave and sky wave propagation?

2x10=20 Marks

**SIXTH SEMESTER BSc ELECTRONIOCS DEGREE EXAMINATION
ELE6B14-PRINCIPLES OF DSP**

Time: 2.5 Hrs.

Max. Marks: 80

Section A

Answer the following Questions (1-15), each carries 2 marks

1. Explain about Direct form I and Direct form II of IIR systems.
2. Differentiate energy and power signal
3. What do you mean by the term causal and non-causal
4. Explain about even and odd signal.
5. Explain the relation between z transform and DFT.
6. Explain about butterfly diagram
7. Differentiate FIR and IIR filter
8. Compare analog and digital filters
9. Mention different representation methods of signals.
10. Describe different test signals.
11. What do you mean by the term cascade and parallel representation
12. Explain Laplace transform
13. What do you mean by the term DTFT
14. Define Z-Transform and its properties
15. Explain any two properties of Laplace transform

Ceiling: 25 Marks

Section B

Answer the following Questions (16-23), each carries 5 marks

16. Explain about DFT and its properties.
17. Brief description about DFT computation techniques.
18. Compute 4 point DFT of sequence $x(n) = \{0, 1, 2, 3\}$ using matrix multiplication method
19. Find the circular convolution of $x_1(n) = \{1, -1, -2, 3, -1\}$, $x_2(n) = \{1, 2, 3\}$ using matrix multiplication method
20. Explain Parseval's theorem
21. Explain linear and circular convolution.
22. Explain overlap add method
23. Brief description about FFT

Ceiling: 35 Marks

Section C

Answer any two questions (24-27), each question carries 10 marks

24. Perform linear convolution of system which has $h(n) = \{1, 1, 1, 2\}$, and $x(n) = \{3, -1, 0, 1, 3, 2, 0, 1, 2, 1\}$ using overlap add method
25. Find 8 point DFT of the sequence $x(n) = \{2, 2, 2, 2, 1, 1, 1, 1\}$ by radix 2 DIT FFT
26. Obtain direct form I and direct form II realization for the system
$$y(n) = x(n) + 0.5x(n-1) + 0.4x(n-2) - 0.6y(n-1) - 0.7y(n-2)$$
27. Explain overlap save method with suitable example

2x10=20 Marks

**SIXTH SEMESTER BSc ELECTRONIOCS DEGREE EXAMINATION
ELE6B15-MICROWAVE THEORY AND TECHNIQUES**

Time: 2.5 Hrs

Max. Marks: 80

Section A

Answer the following Questions (1-15), each carries 2 marks

1. What do you mean by TEM waves?
2. What is the frequency of operation of a microwave oven?
3. What is the difference between group velocity and phase velocity?
4. Give the equation of input impedance of a general transmission line
5. What do you mean by characteristics impedance of a transmission line?
6. Define the term VSWR
7. Give the equation for cut-off frequency of a rectangular waveguide
8. Why TEM waves are prohibited in a rectangular waveguide?
9. What do you mean by the term “standing wave”?
10. Explain the term current modulation is a klystron amplifier
11. What do you mean by bunching diagram?
12. What is mode jumping in a magnetron?
13. Why magnetron is called as a cross field device?
14. What do you mean by Smith chart?
15. Explain the need for a slow wave structure in TWT

Ceiling: 25 Marks

Section B

Answer the following Questions (16-23), each carries 5 marks

16. What are the primary and secondary constants of a transmission line
17. Explain the working of a quarter wave impedance transformer
18. What do you mean by an open circuited and closed circuited transmission line?
19. Explain the working of a Magic Tee
20. With neat diagrams explain the working of a Gunn diode
21. Explain the working of a reflex Klystron using bunching diagram
22. Explain the working of IMPATT diode
23. Explain the modal field distributions of TE_{10} and TM_{11} modes in a waveguide

Ceiling: 35 Marks

Section C

Answer any two questions (24-27), each question carries 10 marks

24. Derive telegraphs equations of a generalized transmission line
25. Explain the working of a two cavity Klystron amplifier
26. Explain the working a cavity magnetron
27. Derive the input impedance of a) quarter wavelength, b) half wavelength, c) open circuited and d) short circuited transmission lines

2x10=20 Marks

**SIXTH SEMESTER BSc ELECTRONIOCS DEGREE EXAMINATION
ELE6B16C – CONTROL SYSTEMS**

Time: 2 Hrs.

Max. Marks: 60

Section A

Answer the following Questions (1-12), each carries 2 marks

1. State Routh Hurwitz stability criterion
2. What is natural frequency and damping ratio?
3. Define Nyquist stability criterion
4. List 3 important properties of Laplace transform
5. State masons gain formula
6. What are test signals?
7. Define poles and zeroes of a transfer function
8. What do you mean by gain margin and phase margin?
9. Explain initial value theorem and final value theorem
10. Write torque balancing equation of:
 - a. Ideal spring
 - b. Ideal dash pot
11. Give any 3 rules in block diagram reduction
12. What are the advantages of Nyquist Plot?

Ceiling: 20Marks

Section B

Answer the following Questions (13-19), each carries 5 marks

13. . Draw and explain position control system
14. What are compensators? Give the transfer function of lead compensator
15. Give the force current analogy between mechanical and electrical systems
16. Explain PID controller
17. Find the overall gain $C(s)/R(s)$ for the signal flow graph shown in figure given below

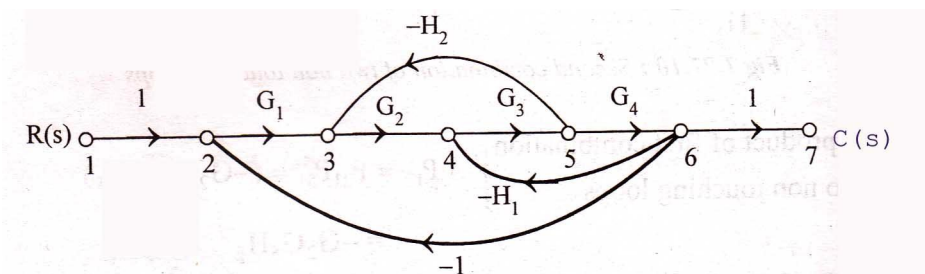

18. What are the classifications of control system?
19. Draw pole zero plot for: $F(s) = \frac{S^2 - S - 2}{S^3 + 5S^2 + 8S + 6}$

Ceiling: 30Marks

Section C
Answer any one question (20-21), carries 10 marks

20. Find the transfer function C/R of the given system

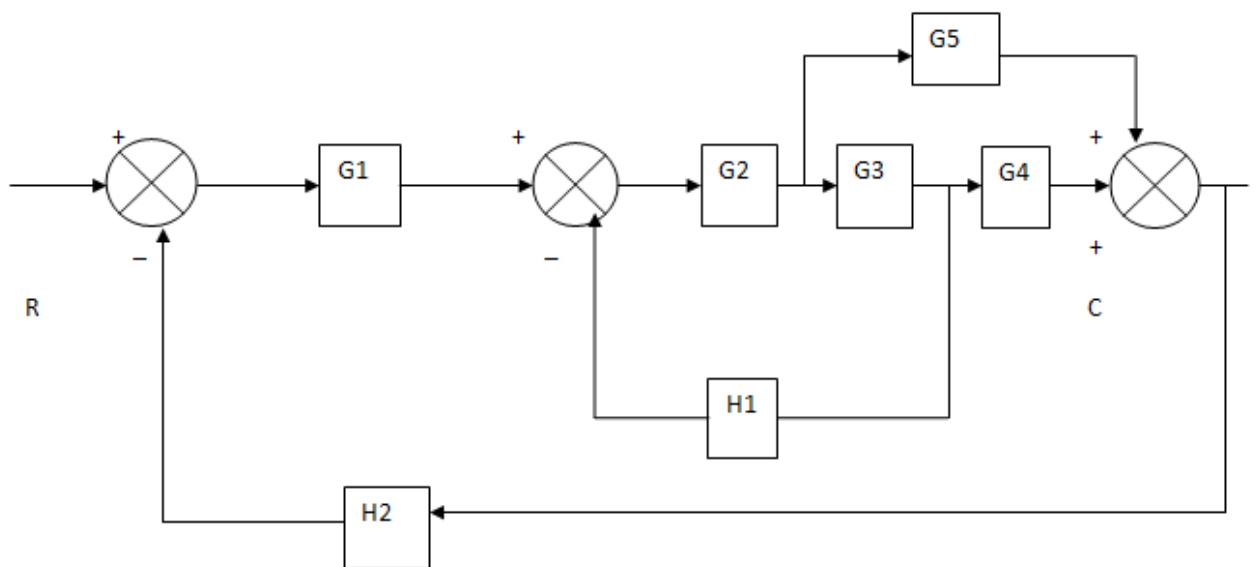

21. Explain the time domain specifications for designing control systems with the help of diagram

1x10=10 Marks